Revised Clinical Study Protocol

Study Code PT001102
NCT # NCT03358147
Date: 08 MARCH 2019

A Randomized, Double-Blind, Parallel Group, Multi-Center 24 Week Study Comparing the Efficacy and Safety of Three Doses of PT001 to Placebo and Open-label Spiriva® Respimat® in Subjects With Persistent Asthma

This submission /document contains trade secrets and confidential commercial information, disclosure of which is prohibited without providing advance notice to AstraZeneca and opportunity to object.

The following Amendment(s) are included in this revised protocol:

Amendment No.	Date of Amendment
Version 1	13 OCTOBER 2017
Version 2, Amendment 1	13 APRIL 2018
Version 3, Amendment 2	07 JUNE2018
Version 4, Amendment 3	22 AUGUST 2018
Version 5, Amendment 4	08 MARCH 2019

Clinical Study Protocol: PT001102-04

Study Title A Randomized, Double-Blind, Parallel Group, Multi-Center 24-Week Study Comparing the Efficacy and Safety of Three Doses of PT001 to Placebo and Open-label Spiriva[®] Respimat[®] in Subjects With Persistent Asthma

Study Number PT001102

Study Phase Phase II/III

Product Name Glycopyrronium Inhalation Aerosol (PT001, GP MDI)

Indication Asthma

Investigators Multicenter

Sponsor Pearl Therapeutics, Inc.
[REDACTED]

Sponsor Contact: [REDACTED]

	Version Number	Date
Original Protocol	Version 1.0	13 October 2017
Amended Protocol #1	Version 2.0	13 April 2018
Amended Protocol #2	Version 3.0	07 June 2018
Amended Protocol #3	Version 4.0	22 August 2018
Amended Protocol #4	Version 5.0	08 March 2019

Confidentiality Statement

Property of Pearl Therapeutics

This document is confidential and may not be used, divulged, published or otherwise disclosed without consent of Pearl Therapeutics Inc.

SUMMARY OF CHANGES TO AMENDED PROTOCOL PT001102-04 (VERSION 5.0), DATED 08 MARCH 2019

The amended study protocol, PT001102-04 (Version 5.0), includes the following edits:

No.	Description of Change	Rationale
1	<p>Removed Visit 5 (Week 4) post-dose vital sign measurements</p> <p>Sections affected: 7.2.2 Vital Sign Measurements 8.1 General Study Considerations (Table 8-2 Sequence and Timing for Selected Assessments at Treatment Visits 4 through 10)</p>	<p>Post-dose spirometry assessment was removed from Visit 5 in Amendment 03, but post-dose vital signs at Visit 5 were left in error. This assessment has now been removed as there should be no post-dose assessments performed at Visit 5.</p>
2	<p>Reduced the time gaps around Visits 1, 2, and 3 by 2 days</p> <p>Sections affected: 4.1 Study Design (Figure 4-1 Study Design Overview) 8.1 General Study Considerations (Table 8-1 Schedule of Events) 8.4 Visit 3 (Day -20 to Day -1)</p>	<p>Holter monitoring sub-study is complete and the extended time gaps around Visits 1, 2, and 3 are no longer needed.</p>
3	<p>Added height requirement at Visits 4, 5, and 7 for subjects 12 to 18 years of age</p> <p>Sections affected: 7.2.1 Medical/Surgical/Asthma Exacerbation History and Physical Examination 8.1 General Study Considerations (Table 8-1 Schedule of Events) 8.5 Visit 4 (Randomization, Day 1) 8.6 Visits 5, 6, 8, and 9 (Weeks 4, 8, 16, and 20) 8.7 Visit 7 (Week 12) 8.8 Final Visit (Visit 10, Week 24)</p>	<p>Height is needed for subjects 12 to 18 years of age in order to calculate creatinine clearance using the Schwartz formula.</p>

No.	Description of Change	Rationale
4	<p>Age range for creatinine clearance equations corrected.</p> <p>Sections affected: 5.2, Exclusion Criterion #13 5.9.1, Reasons for Study Drug Discontinuation 7.2.5, Clinical Laboratory Tests (Table 7-2 List of Clinical Safety Laboratory Tests)</p>	<p>Clarification that subjects 18 years of age should have the Schwartz equation used for creatinine clearance only if the day of the visit is on their 18th birthday.</p>
5	<p>Moved rate of moderate/severe asthma exacerbation from an “other” endpoint to a secondary endpoint and time to first moderate/severe asthma exacerbation from a secondary endpoint to an “other endpoint”</p> <p>Sections affected: Synopsis 3.2 Secondary Efficacy Endpoints 3.3 Other Endpoints 9.5.2.2 Rate of Moderate/Severe Asthma Exacerbations 9.5.3.3 Time to First Asthma Exacerbation 9.5.3.4 Rate of Severe Asthma Exacerbation or Exacerbations of Any Severity</p>	<p>In situations where multiple subjects experiencing an event tend to experience more than one event, an analysis of the event rate is more powerful than an analysis of time to first event. A blinded review of data from this study indicates that there are more events than subjects with at least one event. Hence, the hierarchy order will be switched for the rate and time to first analyses of moderate/severe exacerbations.</p>
6	<p>Changed PEFR analysis at each clinic visit to over 4-week intervals</p> <p>Sections affected: 9.5.3.8 Change from Baseline in Morning PEFR and Evening PEFR</p>	<p>Clarification that PEFR will be analyzed over 4-week intervals</p>
7	<p>Amended censoring wording for CompEx endpoint for remove Day 168</p> <p>Sections affected: 9.5.3.10 CompEx</p>	<p>Clarification that CompEx will be censored at the Week 24 visit only</p>

No.	Description of Change	Rationale
8	Added wording that any clarification to the definition and analysis of consecutive asthma exacerbations will be detailed in the statistical analysis plan	Clarification for definition and analysis of consecutive asthma exacerbations.
9	Made the following modifications to Holter Monitoring Sub-study endpoints: Removed analysis of subjects meeting withdrawal criteria Added endpoint of "Change from baseline in the frequency of supraventricular couplets" Changed "Supraventricular ectopic events" to "Supraventricular ectopic beats" Sections affected: 3.5.2 Secondary Holter Monitoring Sub-Study Endpoints	Clarification of Holter monitoring sub-study endpoints
<i>Other administrative changes to correct and/or clarify protocol language were also addressed. These changes included edits for consistency, grammar, and typographical errors, which are not summarized in this table.</i>		

SYNOPSIS

Sponsor Pearl Therapeutics, Inc. (Pearl) 
Name of Study Drug Glycopyrronium Inhalation Aerosol (PT001, GP metered dose inhaler [GP MDI])
Name of Active Ingredient: Glycopyrronium
Study Title: A Randomized, Double-Blind, Parallel Group, Multi-Center 24-Week Study Comparing the Efficacy and Safety of Three Doses of PT001 to Placebo and Open-label Spiriva [®] Respimat [®] in Subjects With Persistent Asthma
Study Protocol Number: PT001102-04
Study Phase: II/III
Primary Objective: To assess the effect of 3 doses of GP MDI compared to Placebo MDI and Spiriva [®] Respimat [®] on lung function over 24 weeks in subjects with persistent asthma.
Secondary Objective: To assess the effect of 3 doses of GP MDI compared to Placebo MDI and Spiriva Respimat on exacerbations, quality of life, and symptoms over 24 weeks in subjects with persistent asthma.
Safety Objective: To assess the safety of 3 doses of GP MDI compared to Placebo MDI and Spiriva Respimat over 24 weeks in subjects with persistent asthma.
24-Hour Holter Monitoring Sub-Study Objective: To assess the cardiovascular safety of 3 doses of GP MDI compared to Placebo MDI and Spiriva Respimat as evaluated by 24-hour Holter monitoring.
Study Design This Phase II/III randomized, double-blind, parallel group, multi-center, dose confirmation study will compare 3 doses of GP MDI (28.8, 14.4, and 7.2 µg) to Placebo MDI and open-label Spiriva Respimat (2.5 µg). The 3 doses of GP MDI and the Placebo MDI will be administered twice daily (BID) and Spiriva Respimat will be administered once daily (QD), both for 24 weeks. At Visit 1, subjects will sign an informed consent form (ICF) and assent form (as applicable) and inclusion/exclusion criteria will be assessed. All eligible subjects must have been taking a stable regimen of an inhaled corticosteroid (ICS)/long-acting β ₂ -agonist (LABA) for at least 4 weeks, and be willing to continue this medication regimen throughout the trial. Subjects also taking tiotropium 2.5 µg QD for at least 4 weeks prior to Visit 1 may be enrolled if they are willing to discontinue tiotropium at Visit 1. Tiotropium will be replaced with Sponsor-provided ipratropium bromide hydrofluoroalkane (hereafter referred to as ipratropium) taken as 2 inhalations 4 times daily until randomization, when ipratropium will be discontinued. Sponsor-provided

albuterol for rescue use will be dispensed and subjects will begin recording their asthma medications, peak expiratory flow rates, asthma symptom scores, and rescue albuterol use in an electronic diary.

Subjects must demonstrate a forced expiratory volume in 1 second (FEV₁) of >40% and <85% of predicted (>40% and <90% of predicted for subjects 12 to <18 years of age) at Visit 1 (and Visit 2 if spirometry is required), and must demonstrate reversibility to albuterol at Visit 1 or Visit 2.

Subjects will return for Visit 2 after adequate washout of prohibited asthma medications. There will be a minimum of 7 days between Visit 1 and Visit 2. Spirometry will only be performed at Visit 2 if reversibility criteria to albuterol were not met at Visit 1. The Asthma Control Questionnaire (ACQ) will be administered, and multiple other assessments will be made including fractional nitric oxide in inhaled breath (F_{ENO}).

At Visit 3, reversibility of FEV₁ to ipratropium will be assessed for characterization and randomization stratification. For subjects participating in the Holter monitoring sub-study, a 24-hour Holter monitor will also be placed.

At Visit 4, subjects meeting randomization criteria (including demonstrating an FEV₁ of >40% and <85% of predicted [$>40\%$ and $<90\%$ of predicted for subjects 12 to <18 years of age]) will be randomized in a 2:2:2:2:1 scheme to 1 of the following 5 treatment groups:

- GP MDI 28.8 µg BID (double-blind)
- GP MDI 14.4 µg BID (double-blind)
- GP MDI 7.2 µg BID (double-blind)
- Placebo MDI BID (double-blind)
- Spiriva Respimat 2.5 µg QD (open-label)

Randomization will be stratified by baseline percent predicted FEV₁ ($\leq 60\%$ or $>60\%$), reversibility to ipratropium ($<12\%$ or <200 mL vs $\geq 12\%$ and ≥ 200 mL improvement in FEV₁), and by the ICS included in their fixed-dose ICS/LABA combination product (budesonide [eg, Symbicort[®], with formoterol fumarate dihydrate], mometasone furoate [eg, Dulera[®], with formoterol fumarate dihydrate], fluticasone furoate [eg, Breo[®] Ellipta[®], with vilanterol trifenate], or fluticasone propionate [eg, Advair[®] or AirDuo[™] RespiClick[®], with salmeterol]).

Following randomization, subjects will enter the Treatment Period and undergo 6 additional treatment visits over 24 weeks. For subjects participating in the Holter monitoring sub-study, a Holter monitor will be placed at Visit 7 and removed the following day.

Subjects who discontinue randomized study drug prior to the end of the study will be encouraged to remain in the study to complete all remaining study visits and procedures.

24-Hour Holter Monitoring Sub-Study: Holter monitoring will be conducted over 24 hours in a subset of approximately 562 randomized subjects (125 subjects in each GP MDI group and the Placebo MDI group and 62 subjects in the Spiriva Respimat group) at Visit 3 (Holter monitoring baseline) and Visit 7 (Week 12).

Study Population: Approximately 2250 subjects with persistent asthma who are symptomatic despite treatment with a fixed-dose ICS/LABA (\pm tiotropium) will be recruited in order to enroll approximately 1125 subjects into the randomized Treatment Period. This study will be conducted at approximately 250 sites in the United States with each site enrolling approximately 4 to 6 subjects.

Test Product, Dose, Strength, and Mode of Administration

All study drugs will be administered by oral inhalation.

Study Drug (Active and Placebo)

Product Name and Dose	Product Strength	Manufacturer	Dosage Form/ Fill Count	Administration
GP MDI 28.8 μ g	GP MDI 14.4 μ g per actuation	Pearl	MDI/ 120 inhalations	Taken as 2 inhalations BID
GP MDI 14.4 μ g	GP MDI 7.2 μ g per actuation	Pearl	MDI/ 120 inhalations	Taken as 2 inhalations BID
GP MDI 7.2 μ g	GP MDI 3.6 μ g per actuation	Pearl	MDI/ 120 inhalations	Taken as 2 inhalations BID
Placebo MDI	No active ingredient	Pearl ^a	MDI/ 120 inhalations	Taken as 2 inhalations BID
Spiriva [®] Respimat [®] 2.5 μ g	tiotropium bromide 1.25 μ g per actuation	Boehringer Ingelheim Pharmaceuticals, Inc.	Inhalation spray, metered/ 60 inhalations	Taken as 2 inhalations QD

^a Placebo MDIs are manufactured in the image of the active test product.

Duration of Treatment: 24 weeks

Duration of Study: The entire study is scheduled to take approximately 27 to 30 weeks for each subject. The study is anticipated to run for approximately 12 months.

Efficacy Endpoints

Primary Efficacy Endpoint:

- Change from baseline in FEV₁ area under the curve from 0 to 4 hours (AUC₀₋₄) at Week 24

Secondary Efficacy Endpoints

- Change from baseline in morning pre-dose trough FEV₁ at Week 24
- Rate of moderate/severe asthma exacerbations
- Change from baseline in ACQ-7 at Week 24

<ul style="list-style-type: none">• Change from baseline in ACQ-5 at Week 24• Change from baseline in Asthma Quality of Life Questionnaire for 12 years and older (AQLQ +12) at Week 24
Safety Endpoints <ul style="list-style-type: none">• Adverse events• Clinical laboratory values• Vital signs• 12-lead safety electrocardiograms (ECGs)
24-Hour Holter Monitoring Sub-Study Endpoint (Assessed at Week 12) Primary Endpoint <ul style="list-style-type: none">• Change from baseline in mean heart rate over 24 hours
Statistical Methods Primary Efficacy Analysis <p>Change from baseline in FEV₁ AUC₀₋₄ will be analyzed using a linear repeated measures analysis of covariance model for the Efficacy Estimand. The model will include treatment, visit, background ICS/LABA, and treatment by-visit interaction as categorical covariates and baseline FEV₁, percentage reversibility to ipratropium, and blood eosinophil count at screening as continuous covariates.</p> Sample Size <p>A sample size of 1125 subjects (250 subjects per double-blind treatment group, 125 subjects in the open-label Spiriva Respimat treatment group) will provide approximately 93% power to detect a 120 mL difference between the GP MDI treatment groups and Placebo MDI in the analysis of change from baseline in FEV₁ AUC₀₋₄ at Week 24. The assumed standard deviation is 348 mL at each visit. The 2-sided alpha for each pairwise comparison is 0.05. This sample size assumes that approximately 20% of randomized subjects will have discontinued study drug prior to Week 24.</p> <p>Comparisons of GP MDI to Spiriva Respimat will be focused on estimation as the study is not formally powered to demonstrate non-inferiority or superiority.</p>
Data Monitoring Committee: <p>An independent, external Data Monitoring Committee (DMC) will be set up to review all serious adverse events (including deaths and all hospitalizations) and cardiovascular events. Members of the DMC will review summaries of these safety data generated externally and independently of the Sponsor in a semi-blinded or unblinded manner at predetermined intervals. If significant safety issues arise in between scheduled meetings, ad hoc meetings will be scheduled to review the data. Based on the safety implications of the data, the DMC may recommend modification or termination of the study.</p>
Date of Original Approved Protocol: 13 October 2017
Date of Protocol Amendment 1 (Version 2.0): 13 April 2018

Date of Protocol Amendment 2 (Version 3.0): 07 June 2018
Date of Protocol Amendment 3 (Version 4.0): 22 August 2018
Date of Protocol Amendment 4 (Version 5.0): 08 March 2018

TABLE OF CONTENTS

SUMMARY OF CHANGES TO AMENDED PROTOCOL PT001102-04 (VERSION 5.0), DATED 08 MARCH 2019	2
SYNOPSIS.....	5
TABLE OF CONTENTS	10
LIST OF IN-TEXT TABLES	15
LIST OF IN-TEXT FIGURE.....	15
LIST OF APPENDICES	15
LIST OF ABBREVIATIONS AND DEFINITIONS OF TERMS.....	17
1 INTRODUCTION.....	20
1.1 Background Information on the Treatment of Asthma.....	20
2 STUDY OBJECTIVES.....	22
2.1 Primary Objective.....	22
2.2 Secondary Objective	22
2.3 Safety Objective.....	22
2.4 24-Hour Holter Monitoring Sub-Study Objective	22
3 STUDY ENDPOINTS.....	23
3.1 Primary Efficacy Endpoint.....	23
3.2 Secondary Efficacy Endpoints.....	23
3.3 Other Efficacy Endpoints	23
3.4 Safety Endpoints.....	24
3.5 24-Hour Holter Monitoring Sub-Study Endpoints	24
3.5.1 Primary Holter Monitoring Sub-Study Endpoint.....	24
3.5.2 Secondary Holter Monitoring Sub-Study Endpoints.....	24
4 INVESTIGATIONAL PLAN	26
4.1 Study Design.....	26
4.2 Rationale.....	28
4.2.1 Population	28
4.2.2 Choice of Study Doses	28
4.2.3 Choice of Comparators/Control Groups.....	29
4.2.4 Study Duration	29
5 STUDY POPULATION SELECTION	30
5.1 Inclusion Criteria	30
5.2 Exclusion Criteria	31
5.3 Randomization Criteria	33
5.4 Re-Screening Criteria.....	33
5.5 Holter Monitoring Sub-Study Exclusion Criteria.....	33

5.6	Subject Identification	34
5.7	Prior, Concomitant, and Prohibited Medications and Vaccinations	34
5.7.1	Prior Medications	34
5.7.2	Concomitant Medications and Vaccinations	35
5.7.2.1	Vaccinations	35
5.7.2.2	Allowed Medications	35
5.7.3	Prohibited Medications and Washout Periods	37
5.7.3.1	Prohibited Asthma and Allergy Medications and Washout Periods	37
5.7.3.2	Prohibited Non-Asthma and Non-Respiratory Medications and Washout Periods	37
5.8	Other Restrictions, Illicit Drugs, and Drugs of Abuse	39
5.8.1	Illicit Drugs or Drugs of Abuse	39
5.8.2	Dietary Restrictions	39
5.9	Reasons for Study Drug Discontinuation or Study Withdrawal	39
5.9.1	Reasons for Study Drug Discontinuation	39
5.9.2	Reasons for Study Withdrawal	40
6	CLINICAL SUPPLY LABELING, PACKAGING, STORAGE, DISPENSING, AND RETURN	41
6.1	Description of Study Drugs	41
6.2	Other Sponsor-Provided Medications Used in the Study	42
6.3	Packaging and Labeling	43
6.3.1	Primary Packaging and Labeling	43
6.3.2	Secondary Packaging and Labeling	43
6.4	Storage Requirements	43
6.5	Instructions for Dispensing and Preparation of Study Drugs for Administration	44
6.6	Emergency Unblinding	45
6.7	Drug Accountability/Return of Clinical Supplies	45
7	STUDY PROCEDURES	47
7.1	Efficacy Assessments	47
7.1.1	Pulmonary Function Tests	47
7.1.1.1	Spirometry Standardization	47
7.1.1.2	Spirometry Schedule	48
7.1.1.3	Reversibility to Albuterol and Ipratropium	49
7.1.2	Subject's eDiary Data Collection	49
7.1.2.1	eDiary Compliance Requirement	50
7.1.2.2	Rescue Medication Use	50
7.1.2.3	PEFR	50
7.1.2.4	Asthma Symptoms	51
7.1.2.5	Study Drug and Other Study Medication Compliance	52
7.1.2.6	Symptom Worsening Assessment and eDiary Alert System	52

7.1.3	Asthma Exacerbations	52
7.1.3.1	Definitions and Treatments	52
7.1.3.2	Onset and Duration of Asthma Exacerbations	54
7.1.3.3	Approach for Capturing Asthma Exacerbations.....	54
7.1.4	Subject Questionnaires	55
7.1.4.1	ACQ	55
7.1.4.2	AQLQ +12	55
7.1.5	F _{ENO}	56
7.2	Safety Assessments	56
7.2.1	Medical/Surgical/Asthma Exacerbation History and Physical Examination	56
7.2.2	Vital Sign Measurements.....	57
7.2.3	12-Lead ECG	57
7.2.4	Holter Monitoring: 24-Hour Continuous Electrocardiography	58
7.2.4.1	Visit 3 Holter Monitoring Procedures	58
7.2.4.2	Visit 7 Holter Monitoring Procedures	59
7.2.4.3	Data for Analysis	59
7.2.5	Clinical Laboratory Tests	59
7.3	AEs.....	62
7.3.1	Performing AE Assessments.....	62
7.3.2	AE Definitions	62
7.3.3	Pre-Randomization AEs	63
7.3.4	Severity	63
7.3.5	Relationship to Study Drug.....	63
7.3.6	Asthma Exacerbations and Associated Symptoms of Asthma	63
7.3.7	AEs of Special Interest	64
7.3.7.1	LAMA Effects.....	64
7.3.7.2	Paradoxical Bronchospasm	64
7.3.8	Clinical Laboratory AEs	64
7.3.9	SAEs	65
7.3.9.1	Reporting SAEs	65
7.3.9.2	Supplemental Investigations of SAEs.....	66
7.3.9.3	Notification of Post-Study SAEs	66
7.3.9.4	Institutional Review Board/Independent Ethics Committee Notification of SAEs.....	66
7.3.9.5	Health Authority Safety Reports	67
7.3.10	Post-Study Follow-Up of AEs and SAEs	67
7.3.11	Overdose	67
7.3.12	Pregnancy.....	67
7.3.13	Paternal Exposure.....	67
7.3.14	Hy’s Law	68

7.3.15	Data Monitoring Committee	68
7.4	Termination of Study	68
8	STUDY ACTIVITIES	69
8.1	General Study Considerations	69
8.2	Visit 1 (Day -28 to -9).....	78
8.3	Visit 2 (Day -21 to Day -2)	79
8.4	Visit 3 (Day -20 to Day -1)	80
8.5	Visit 4 (Randomization, Day 1).....	81
8.6	Visits 5, 6, 8, and 9 (Weeks 4, 8, 16, and 20).....	83
8.7	Visit 7 (Week 12).....	84
8.8	Final Visit (Visit 10, Week 24).....	86
8.9	Procedures for Treatment Discontinuation and Study Withdrawal Visits	87
8.9.1	Treatment Discontinuation	87
8.9.2	Study Withdrawal.....	87
8.9.3	Study Visit Procedures	87
8.10	Repeat Assessments and Treatment Discontinuation and/or Study Withdrawal Visits	88
8.11	Follow-Up Telephone Call.....	88
8.12	Completion of the Study	88
9	STATISTICAL METHODS	90
9.1	Introduction	90
9.2	Protocol Variables.....	90
9.3	Analysis Sets and Estimands	90
9.3.1	Analysis Sets.....	90
9.3.2	Estimands.....	91
9.4	Demographic and Baseline Characteristics	92
9.5	Efficacy Analysis	92
9.5.1	Primary Efficacy Analysis	92
9.5.1.1	Change From Baseline in FEV ₁ AUC ₀₋₄	92
9.5.2	Secondary Efficacy Analysis	93
9.5.2.1	Change From Baseline in Morning Pre-Dose Trough FEV ₁	93
9.5.2.2	Rate of Moderate/Severe Asthma Exacerbations	93
9.5.2.3	Change From Baseline in ACQ-7, ACQ-5, and AQLQ +12	93
9.5.3	Other Efficacy Analyses	93
9.5.3.1	Percentage of Responders in ACQ-5, ACQ-6, ACQ-7, and AQLQ +12	93
9.5.3.2	Change from Baseline in ACQ-6.....	94
9.5.3.3	Time to First Asthma Exacerbation.....	94
9.5.3.4	Rate of Severe Asthma Exacerbations or Exacerbations of Any Severity	94

9.5.3.5	Peak FEV ₁	94
9.5.3.6	Percentage of Symptom-Free Days, Rescue-Free Days, and Asthma Control Days.....	94
9.5.3.7	Rescue Medication Usage.....	95
9.5.3.8	Change From Baseline in Morning PEFr and Evening PEFr.....	95
9.5.3.9	F _{ENO}	95
9.5.3.10	CompEx	96
9.5.4	Subgroup Analyses.....	96
9.5.5	Type I Error Control.....	96
9.6	Safety Analysis	97
9.6.1	AEs	97
9.6.2	AESIs.....	97
9.6.3	Clinical Laboratory Measurements	97
9.6.4	Vital Signs.....	97
9.6.5	ECGs.....	97
9.6.6	24-Hour Holter Monitoring	97
9.7	Sample Size Consideration.....	98
9.8	Data Validation and Transformation.....	98
9.9	Analysis Plan	99
9.10	Blinded Sample Size Re-Estimation.....	99
9.11	Interim Analysis.....	99
9.12	Handling of Missing Data	99
9.13	Statistical Software	99
10	ADMINISTRATIVE CONSIDERATIONS.....	100
10.1	Regulatory Authority Approval.....	100
10.2	Ethical Conduct of the Study and IRB or IEC Approval.....	100
10.3	Subject Informed Consent	100
10.4	Laboratory Accreditation	101
10.5	Confidentiality	101
10.5.1	Confidentiality of Data	101
10.5.2	Confidentiality of Subject Records	101
10.6	Quality Control and Assurance.....	101
10.7	Data Management	102
10.8	Study Monitoring	102
10.9	Retention of Data.....	103
10.10	Financial Disclosure.....	103
10.11	Investigator’s Final Report.....	103
10.12	Publication and Disclosure Policy	103
11	REFERENCE LIST.....	105

12 APPENDICES..... 107

LIST OF IN-TEXT TABLES

Table 5-1	Permitted ICS Dosages in Fixed-Dose Combination Products With LABA.....	35
Table 5-2	Allowed Asthma Medications With Required Holding Periods Prior to Visit 2 and All Subsequent Visits.....	36
Table 5-3	Allowed Asthma and Allergy Medications.....	36
Table 5-4	Prohibited Asthma and Allergy Medications and Required Washout Period Prior to Visit 2.....	37
Table 5-5	Prohibited Non-Asthma and Non-Respiratory Medications and Required Washout Period Prior to Visit 1.....	38
Table 6-1	Randomized Study Drugs.....	42
Table 6-2	Other Sponsor-Provided Study Medications.....	42
Table 7-1	Definition and Severity of Asthma Exacerbations.....	53
Table 7-2	List of Clinical Safety Laboratory Tests.....	61
Table 8-1	Schedule of Events.....	71
Table 8-2	Sequence and Timing for Selected Assessments at Treatment Visits 4 through 10.....	75
Table 8-3	Schedule of Events for 24-hour Holter Monitoring Sub-Study at Visits 3 and 7.....	77

LIST OF IN-TEXT FIGURE

Figure 4-1	Study Design Overview.....	26
------------	----------------------------	----

LIST OF APPENDICES

Appendix 1	Body Mass Index Calculators.....	108
Appendix 2	Spirometry Assessment Criteria.....	109
Appendix 3	Spirometry Performance Recommendations.....	111
Appendix 4	Dose-Indicator Reading for GP MDI and Placebo MDI.....	117
Appendix 5	Instructions for Use of GP MDI and Placebo MDI.....	118
Appendix 6	Instructions for Use of Spiriva [®] Respimat [®] (tiotropium) Inhalation Spray.....	127
Appendix 7	Instructions for Use of Ventolin [®] HFA (albuterol) Inhaler.....	133
Appendix 8	Instructions for Use of Atrovent [®] HFA (ipratropium) Inhaler.....	144

Appendix 9	Asthma Control Questionnaire (ACQ)	149
Appendix 10	Asthma Quality of Life Questionnaire for 12 Years and Older (AQLQ +12)	152
Appendix 11	Fractional Nitric Oxide in Inhaled Breath.....	158
Appendix 12	Rules for Evaluation of Abnormal Liver Laboratory Values.....	159
Appendix 13	Sponsor Signatory.....	162
Appendix 14	Investigator’s Agreement and Signature Page	163

LIST OF ABBREVIATIONS AND DEFINITIONS OF TERMS

ACQ	Asthma Control Questionnaire
ACQ-5	ACQ questions 1 through 5, which measure the frequency, intensity or limitations from asthma symptoms using 1-week recall
ACQ-6	ACQ questions 1 through 6, which is the ACQ-5 plus 1 item that scores the average number of daily puffs needed from rescue medication using 1-week recall
ACQ-7	ACQ questions 1 through 7, which is the ACQ-6 plus 1 item that scores lung function (FEV ₁ percent predicted)
AE	Adverse event
AESI	Adverse event of special interest
ALT	Alanine aminotransferase
ANCOVA	Analysis of covariance
AQLQ +12	Asthma Quality of Life Questionnaire for 12 years and older
AST	Aspartate aminotransferase
ATS	American Thoracic Society
AUC ₀₋₄	Area under the curve from 0 to 4 hours
BID	Twice daily
CFR	Code of Federal Regulations
CKD-EPI	Chronic Kidney Disease Epidemiology Collaboration
CompEx	A composite endpoint comprising clinically relevant deteriorations and severe exacerbations in asthma
DBP	Diastolic blood pressure
DMC	Data Monitoring Committee
ECG	Electrocardiogram
eCRF	Electronic case report form
eDiary	Electronic diary
ER	Emergency room
ERS	European Respiratory Society
FDA	Food and Drug Administration
FE _{NO}	Fractional nitric oxide concentration in exhaled breath

FEV ₁	Forced expiratory volume in 1 second
FVC	Forced vital capacity
GCP	Good Clinical Practice
GINA	Global Initiative for Asthma
GP MDI	Glycopyrronium Inhalation Aerosol
hCG	Human chorionic gonadotropin
HFA	Hydrofluoroalkane
HR	Heart rate
IB	Investigator brochure
ICF	Informed consent form
ICH	International Conference on Harmonisation
ICMJE	International Committee of Medical Journal Editors
ICS	Inhaled corticosteroid
IEC	Independent Ethics Committee
IRB	Institutional Review Board
ISMPP	International Society for Medical Publication Professionals
ITT	Intent-to-Treat
IWRS	Interactive web response system
LABA	Long-acting β_2 -agonist
LAMA	Long-acting muscarinic antagonist
MDI	Metered dose inhaler
MedDRA	Medical Dictionary for Regulatory Activities
mITT	Modified Intent-to-Treat
NSVT	Non-sustained ventricular tachycardia
PEFR	Peak expiratory flow rate
PFT	Pulmonary function test
PIN	Personal identification number
PVC	Premature ventricular contraction
QD	Once daily

QID	Four times daily
QTcF	Fridericia-corrected QT interval
SABA	Short-acting β_2 -agonist
SAE	Serious adverse event
SAMA	Short-acting muscarinic antagonist
SAP	Statistical analysis plan
SBP	Systolic blood pressure
SD	Standard deviation
TBL	Total bilirubin
ULN	Upper limit of normal
US	United States

1 INTRODUCTION

The Sponsor is developing a family of orally inhaled drug products containing budesonide, glycopyrronium, and/or formoterol fumarate as single agents, dual combinations, and a triple combination product. These drug products are metered dose inhalers (MDIs) formulated as a suspension with micronized active pharmaceutical ingredients and Co-Suspension™ Delivery Technology. The Co-Suspension Delivery Technology consists of spray-dried porous particles comprised of the phospholipid 1,2-distearoyl-sn-glycero-3-phosphocholine and calcium chloride suspended in a hydrofluoroalkane (HFA) propellant. When used in combination MDI products, these particles form strong non-specific associations with the active pharmaceutical ingredients, preventing the drugs from interacting with each other in the suspension and providing reproducible drug delivery and long-term stability.

The test formulation to be evaluated in this study is an MDI containing Glycopyrronium Inhalation Aerosol (henceforth referred to as GP MDI), a long-acting muscarinic antagonist (LAMA). Further details about the to-be-tested formulations are provided in [Table 6-1](#) and the current version of the PT001 investigator brochure (IB).

1.1 Background Information on the Treatment of Asthma

Asthma is a heterogeneous disease that is characterized by chronic airway inflammation and bronchial hyperreactivity. It is defined by a history of respiratory symptoms such as wheeze, shortness of breath, chest tightness, and cough that vary over time and in intensity, together with variable expiratory airflow obstruction. The variations in symptoms and airflow obstruction are often triggered by factors such as exercise, allergen or irritant exposure, changes in weather, noxious fumes, or viral respiratory infections. Symptoms and airflow obstruction may resolve spontaneously or in response to therapy. Importantly, worsening asthma symptoms/airway obstruction can be severe, resulting in an asthma exacerbation that may be life-threatening. Such events pose a significant burden to patients and result in significant direct and indirect economic costs (Global Initiative for Asthma [GINA] 2017).

The main objective of asthma treatment is to maintain asthma control (GINA 2017). The concept of ‘asthma control’ is not synonymous with ‘asthma severity’ and is defined as ‘the extent to which the various manifestations of asthma have been reduced or removed by treatment’. This concept encompasses 2 components: the patient’s recent clinical status/current disease impact (symptoms, night awakenings, use of rescue medication, and lung function) and future risk (exacerbations, decline in lung function, or treatment-related side effects). According to the GINA guidelines, asthma is controlled when a patient has daytime symptoms twice or less per week, no limitation of daily activities, no nocturnal symptoms, no exacerbations, the need for rescue medication use is twice or less per week, and normal or near normal lung function.

The GINA guidelines specify 5 treatment steps for asthma, each step outlining options for higher levels of treatment for controlling asthma in patients 5 years of age and older (GINA 2017). Within this stepwise approach, GINA proposes a classification of asthma severity based on the type and intensity of controller medication required for the control of

the disease (Steps 1 to 5). The GINA guidelines also propose a classification in 3 categories (mild, moderate, and severe asthma) assessed retrospectively once the patient is on regular controller treatment for several months.

Per GINA guidelines, the goal of the stepwise approach to treatment is to achieve and maintain control. In this regard, the level of asthma control obtained with treatment determines the need to step up or step down to the next treatment step in order to achieve optimum control with the minimum amount of medication. The majority of asthma patients can achieve and maintain clinical control with standard treatment regimens that generally include inhaled corticosteroids (ICSs) with or without inhaled long-acting β_2 -agonists (LABAs) as well as short-acting β_2 -agonists (SABAs). However, some patients with asthma have inadequately controlled disease despite the use of an ICS with or without a LABA. Treatment options that may be considered in these patients include adding a LAMA such as tiotropium and, in certain subsets of patients, biologic agents (eg, omalizumab, mepolizumab), bronchial thermoplasty, and low-dose oral corticosteroids (GINA 2017).

This information indicates that LAMAs have a significant role in the management of asthma when used in combination with other controller medications (Barnes 2011). The goal of the current study is to evaluate the safety and efficacy of 3 doses of GP MDI in comparison to Placebo MDI and Spiriva[®] Respimat[®] over 24 weeks in subjects whose asthma is not optimally controlled despite treatment with an ICS/LABA or an ICS/LABA plus tiotropium.

2 STUDY OBJECTIVES

2.1 Primary Objective

- To assess the effect of 3 doses of GP MDI compared to Placebo MDI and Spiriva[®] Respimat[®] on lung function over 24 weeks in subjects with persistent asthma

2.2 Secondary Objective

- To assess the effect of 3 doses of GP MDI compared to Placebo MDI and Spiriva Respimat on exacerbations, quality of life, and symptoms over 24 weeks in subjects with persistent asthma

2.3 Safety Objective

- To assess the safety of 3 doses of GP MDI compared to Placebo MDI and Spiriva Respimat over 24 weeks in subjects with persistent asthma

2.4 24-Hour Holter Monitoring Sub-Study Objective

- To assess the cardiovascular safety of 3 doses of GP MDI compared to Placebo MDI and Spiriva Respimat as evaluated by 24-hour Holter monitoring

3 STUDY ENDPOINTS

3.1 Primary Efficacy Endpoint

- Change from baseline in forced expiratory volume in 1 second (FEV₁) area under the curve from 0 to 4 hours (AUC₀₋₄) at Week 24

3.2 Secondary Efficacy Endpoints

- Change from baseline in morning pre-dose trough FEV₁ at Week 24
- Rate of moderate/severe asthma exacerbations
- Change from baseline in Asthma Control Questionnaire (ACQ)–7 at Week 24
- Change from baseline in ACQ-5 at Week 24
- Change from baseline in Asthma Quality of Life Questionnaire for 12 years and older (AQLQ +12) at Week 24

3.3 Other Efficacy Endpoints

With the exception of rate of moderate/severe asthma exacerbation, all of the primary and secondary endpoints shown above will also be assessed over the Treatment Period and at each clinic visit as other efficacy endpoints.

In addition, the following endpoints will be assessed over the Treatment Period, by visit for measures assessed at clinic visits (with the exception of responder endpoints, which will be assessed at Week 24 and over the Treatment Period), and over each 4-week interval for measures assessed by electronic diary (eDiary) unless specified otherwise below.

- Percentage of responders in ACQ-5 (≥ 0.5 change equals response)
- Change from baseline in ACQ-6
- Percentage of responders in ACQ-6 (≥ 0.5 change equals response)
- Percentage of responders in ACQ-7 (≥ 0.5 change equals response)
- Percentage of responders in AQLQ +12 (≥ 0.5 change equals response)
- Time to first moderate/severe asthma exacerbation (assessed over the Treatment Period only)
- Time to first severe asthma exacerbation (assessed over the Treatment Period only)
- Rate of severe asthma exacerbations (assessed over the Treatment Period only)
- Time to first asthma exacerbation of any severity (assessed over the Treatment Period only)

- Rate of asthma exacerbations of any severity (assessed over the Treatment Period only)
- Peak FEV₁
- Percentage of symptom-free days (24-hour period without symptoms)
- Percentage of rescue-free days (24-hour period without rescue medication use)
- Change from baseline in the mean number of puffs of rescue medication use (puffs/day)
- Percentage of asthma control days (24-hour period without rescue medication or symptoms)
- Change from baseline in morning peak expiratory flow rate (PEFR)
- Change from baseline in evening PEFR
- Change from baseline in fractional nitric oxide concentration in exhaled breath (F_{ENO})
- Percentage of clinically meaningful changes from baseline in F_{ENO}
- Time to first CompEx event

3.4 Safety Endpoints

- Adverse events (AEs)
- Clinical laboratory values
- Vital signs
- 12-lead safety electrocardiograms (ECGs)

3.5 24-Hour Holter Monitoring Sub-Study Endpoints

3.5.1 Primary Holter Monitoring Sub-Study Endpoint

- Change from baseline in mean heart rate (HR) over 24 hours

3.5.2 Secondary Holter Monitoring Sub-Study Endpoints

- Change from baseline in mean nighttime (22:00 to 06:00) and daytime (06:00 to 22:00) HR
- Change from baseline in the maximum 24-hour HR
- Change from baseline in the minimum 24-hour HR
- Change from baseline in the frequency of isolated ventricular events (premature ventricular contractions [PVCs])

- Change from baseline in the frequency of ventricular couplets (defined as 2 PVCs preceded or followed by regular beats)
- Change from baseline in the frequency of ventricular runs (defined as 3 or more PVCs preceded or followed by regular beats)
- Change from baseline in the frequency of supraventricular couplets
- Change from baseline in frequency of isolated supraventricular events
- Change from baseline in the frequency of supraventricular ectopic beats
- Change from baseline in the frequency of supraventricular runs
- Incidence of atrial fibrillation with rapid ventricular response (>100 bpm)
- Proportion of subjects with maximum HR >180, >160 to 180, >140 to 160, >120 to 140, >100 to 120, and 100 bpm or less
- Proportion of subjects with minimum HR >60, >50 to 60, >40 to 50, and <40 bpm
- Proportion of subjects in each category of change from baseline in the number of PVCs per hour (no change; increase of >0 to <60, 60 to <120, and \geq 120; and decrease of >0 to <60, 60 to <120, and \geq 120)

4 INVESTIGATIONAL PLAN

4.1 Study Design

This is a Phase II/III randomized, double-blind, parallel group, multi-center dose confirmation study comparing 3 doses of GP MDI (28.8, 14.4, and 7.2 µg) to Placebo MDI and open-label Spiriva Respimat (2.5 µg) in subjects with persistent asthma who are symptomatic despite treatment with an ICS/LABA or ICS/LABA + tiotropium. The 3 doses of GP MDI and the Placebo MDI will be administered twice daily (BID) and Spiriva Respimat will be administered once daily (QD), each for 24 weeks. The subject will also continue on their own ICS/LABA regimen during the Screening Period and throughout the Treatment Period.

Figure 4-1 displays the overall study design.

Figure 4-1 Study Design Overview

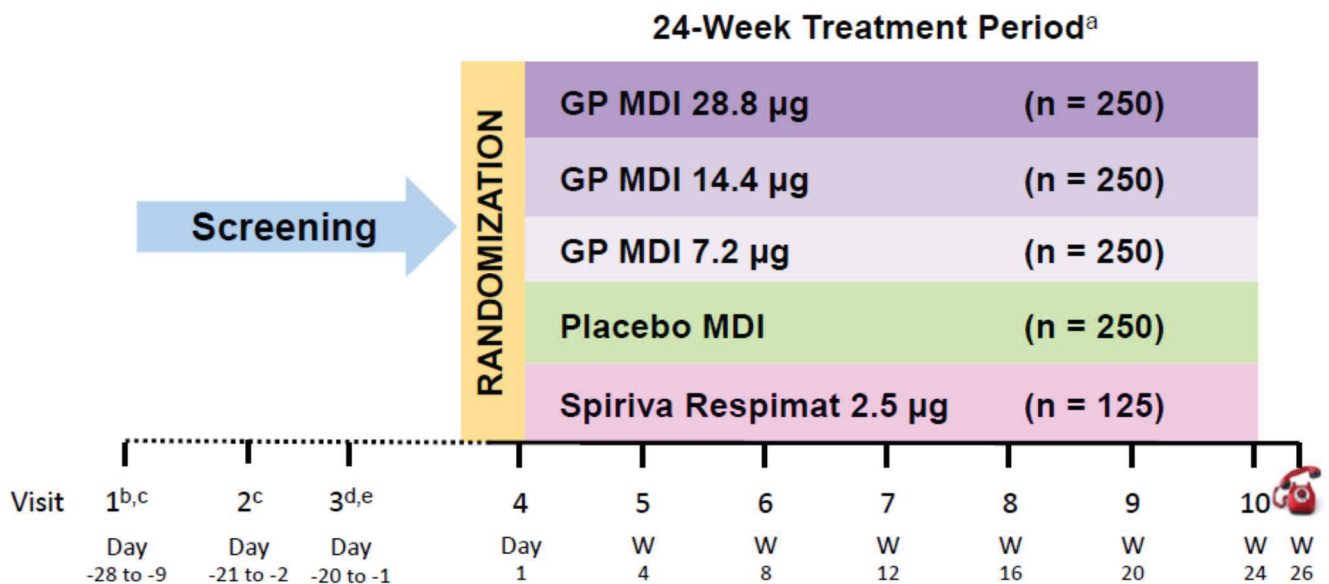

Abbreviations: W=week.

^a All GP MDI and Placebo MDI treatments are double-blind; Spiriva Respimat is open-label; all subjects will be on a fixed combination ICS/LABA during Screening and throughout the study

^b For subjects on tiotropium, discontinue tiotropium and dispense ipratropium

^c Subject must demonstrate reversibility to albuterol at either Visit 1 or Visit 2 for study eligibility

^d Reversibility testing to ipratropium for characterization and stratification only

^e Holter to be placed at Visits 3 and 7 and removed the following day

This study will be conducted at approximately 250 sites, contributing approximately 4 to 6 subjects per site. It is planned that approximately 2250 prospective subjects will be screened, with approximately 1125 subjects randomized to provide approximately 900 subjects who complete the study.

At Visit 1, subjects (or the parents or legal guardians of subjects <18 years of age) will sign an informed consent form (ICF); subjects <18 years of age will sign an assent form. All eligible subjects must be taking a stable regimen of an inhaled corticosteroid (ICS)/long-acting β 2-agonist (LABA) for at least 4 weeks; this ICS/LABA regimen will be continued throughout the Screening and randomized Treatment Periods. Subjects who are also taking tiotropium will discontinue its use at Visit 1 and replace tiotropium with Sponsor-provided ipratropium bromide HFA MDI (hereafter referred to as ipratropium) taken as 2 inhalations 4 times daily (QID) during the Screening Period. Beginning with Visit 1, subjects will use an eDiary BID to record ICS/LABA use (Screening Period only), albuterol sulfate HFA MDI (hereafter referred to as albuterol) use, asthma symptom scores, PEFr, and study drug use (Treatment Period only).

Subjects must demonstrate an FEV₁ >40% and <85% of predicted (>40% and <90% of predicted for subjects 12 to <18 years of age) at Visit 1, Visit 2 (if applicable) and Visit 4. Reversibility to albuterol must be demonstrated at either Visit 1 or Visit 2. A subject will be considered reversible to albuterol if the improvement in FEV₁ from pre-albuterol to post-albuterol is \geq 12% and \geq 200 mL (Section 7.1.1.3).

Subjects will return for Visit 2 after adequate washout of prohibited asthma medications. There will be a minimum of 7 days between Visit 1 and Visit 2. At Visit 2, the ACQ will be administered along with multiple other assessments including FE_{NO}. Spirometry will only be performed at Visit 2 if reversibility to albuterol was not demonstrated at Visit 1.

A subset of approximately 562 subjects (125 subjects from the GP MDI groups and Placebo MDI group and 62 subjects from the Spiriva Respimat group) will participate in the 24-hour Holter monitor sub-study. In these subjects, a 24-hour Holter monitor will be collected between Visit 3 and Visit 4 (Holter Monitor Baseline) and at Visit 7 (Week 12). Those subjects who have clinically significant abnormal findings defined as (but not limited to) criteria in Section 5.5 during the baseline 24-hour Holter monitor MUST be screen failed from the full study. Subjects unable to provide a minimum of 18 hours of acceptable quality recording in a 24-hour period after 2 attempts will not be eligible for the Holter monitoring sub-study, but DO NOT need to be screen failed from the full study.

Reversibility to ipratropium will be assessed at Visit 3 for characterization and randomization stratification purposes. For subjects participating in the Holter monitoring sub-study, a 24-hour Holter monitor will also be placed at Visit 3 (Section 7.2.4) and removed the following day.

Subjects meeting randomization criteria at Visit 4 (Section 5.3) will continue to take their same ICS/LABA regimen throughout the randomized Treatment Period, discontinue ipratropium (if applicable), and be randomized in a 2:2:2:2:1 scheme to 1 of the following 5 treatment groups for 24 weeks:

- GP MDI 28.8 μ g BID (n=250)
- GP MDI 14.4 μ g BID (n=250)

- GP MDI 7.2 µg BID (n=250)
- Placebo MDI BID (n=250)
- Spiriva Respimat 2.5 µg QD (n=125)

Randomization will be stratified by baseline percent predicted FEV₁ ($\leq 60\%$ or $>60\%$), reversibility to ipratropium ($<12\%$ or <200 mL vs $\geq 12\%$ and ≥ 200 mL improvement in FEV₁), and by the ICS included in their fixed-dose ICS/LABA combination product (budesonide [eg, Symbicort[®], with formoterol fumarate dihydrate], mometasone furoate [eg, Dulera[®], with formoterol fumarate dihydrate], fluticasone furoate [eg, Breo[®] Ellipta[®], with vilanterol trifenate], or fluticasone propionate [eg, Advair[®] or AirDuo[™] RespiClick[®], with salmeterol]).

Following randomization, subjects will undergo 6 additional treatment visits over 24 weeks. For subjects participating in the Holter monitoring sub-study, a Holter monitor will be placed at Visit 7 (Section 7.2.4) and removed the following day.

Note: The end of study is defined as the date on which data are collected 14 (+2) days after the last dose of study drug. Data collection can occur via a follow-up telephone call (Section 8.11) or a study visit, whichever provides 14 (+2) days of follow-up.

4.2 Rationale

GP MDI is being developed for use in the treatment of asthma. This study will characterize the efficacy and safety of GP MDI, evaluating multiple doses in order to determine the most appropriate GP MDI dose(s) to treat subjects with asthma who remain symptomatic despite treatment with an ICS/LABA.

4.2.1 Population

The primary intended use of GP MDI in asthma will be as add-on therapy to ICS/LABA in line with GINA guidelines (GINA 2017). This study will include subjects with persistent asthma who remain symptomatic, as demonstrated by an ACQ-5 (see Section 7.1.4.1) total score ≥ 1.5 , despite treatment with an ICS/LABA. Symptomatic subjects receiving tiotropium in addition to an ICS/LABA are also included in order to cover the spectrum of asthma severity for which the addition of a LAMA to an ICS/LABA may be appropriate.

4.2.2 Choice of Study Doses

Efficacy and safety data from Phase I and II studies indicate that GP MDI 28.8, 14.4, and 7.2 µg administered BID may be appropriate doses to evaluate in a Phase III study in subjects with uncontrolled persistent asthma despite treatment with an ICS/LABA. In a Phase II study, GP MDI 28.8 µg was most similar to salmeterol, the active comparator, for all outcome measures, and the GP MDI 14.4 and 7.2 µg doses were similar to salmeterol for some endpoints. GP MDI doses below 7.2 µg were appreciably less effective than salmeterol. The previous GP MDI Phase II study included subjects with asthma who were either on a

low dose of an ICS or not on an ICS. Therefore, confirmation of the optimal GP MDI dose in subjects with uncontrolled persistent asthma despite treatment with an ICS/LABA is warranted.

Doses above 28.8 µg have not been evaluated in subjects with asthma, and thus, the 28.8 µg dose is the highest dose planned for evaluation in this study. Furthermore, based on data from prior Phase I and Phase II studies, doses below 7.2 µg are not expected to have appreciable efficacy, and thus, the 7.2 µg dose is the lowest dose planned for inclusion in the study.

Refer to the current PT001 IB for further details on the Phase I and Phase II GP MDI studies.

The dose chosen for Spiriva Respimat, 2.5 µg QD, is the approved dose in the current prescribing information for the treatment of asthma in individuals 6 years of age and older (Spiriva Respimat 2017).

4.2.3 Choice of Comparators/Control Groups

Spiriva Respimat will be included in this study as an active comparator to benchmark the GP MDI results. Placebo MDI will serve as the control arm.

4.2.4 Study Duration

The specified study duration of 24 weeks will provide sufficient time to observe lung function changes in the chosen subject population. This is based on previous studies with tiotropium in asthma demonstrating that lung function changes plateau in 6 to 8 weeks and do not increase further in studies of up to 48 weeks in duration (Kerstjens 2015, Kerstjens 2012).

5 STUDY POPULATION SELECTION

5.1 Inclusion Criteria

Each subject must meet the following criteria in relationship to Visit 1, unless otherwise noted, to be enrolled in this study:

1. Give their signed written informed consent (and assent as appropriate) to participate
2. Are at least 12 years of age and no older than 80 years
3. Have a documented history of physician-diagnosed asthma
4. Require inhaled asthma maintenance therapy: has been regularly using an ICS/LABA on a stable regimen, with the ICS doses allowed in [Table 5-1](#), for at least 4 weeks prior. Subjects may be included if also receiving tiotropium 2.5 µg QD for at least 4 weeks prior.
5. ACQ-5 total score ≥ 1.5 at Visit 2
6. Based on the average of 2 assessments, pre-bronchodilator FEV₁ $>40\%$ and $<85\%$ of predicted normal value for subjects 18 to 80 years of age or $>40\%$ and $<90\%$ of predicted for subjects 12 to <18 years of age at Visits 1, 2 (if applicable), and 4
7. Documented reversibility to albuterol (defined as a post-albuterol increase in FEV₁ of $\geq 12\%$ and ≥ 200 mL) at either Visit 1 or Visit 2
8. At Visits 1, 2 (if applicable), and 4 (pre-randomization), demonstrate both:
 - Acceptable spirometry performance (ie, meet American Thoracic Society [ATS]/European Respiratory Society [ERS] acceptability criteria; [Appendix 3](#))
 - FEV₁ repeatability at one of the pre-dose measurements
9. Willing and, in the opinion of the Investigator, able to adjust current asthma therapy, as required by the protocol
10. Demonstrate acceptable MDI administration technique
Note: Use of a spacer device during the Screening and randomized Treatment Periods is not permitted.
11. Body mass index <40 kg/m² (see calculators in [Appendix 1](#))
12. Agree to 1 of the following to prevent pregnancy:
 - Non-childbearing potential (ie, physiologically incapable of becoming pregnant, including any female who is 2 years post-menopausal, or surgically sterile [defined as having a bilateral oophorectomy, hysterectomy, or tubal ligation])
Note: For purposes of this protocol, menopausal women are defined as women ≥ 50 years old who are amenorrheic for 12 consecutive months or more following cessation of all exogenous hormonal treatment
 - Practice abstinence
 - If a heterosexual female of childbearing potential and sexually active, agrees to prevent pregnancy by using 1 of the following methods of birth control from the date the ICF is signed until 2 weeks after the final dose of study drug is taken:

- Hormonal contraception (eg, oral contraceptive, contraceptive implant, or injectable hormonal contraceptive)
 - Double-barrier birth control (eg, condom plus intrauterine device, diaphragm plus spermicide, or condom plus spermicide)
 - Maintenance of a monogamous sexual relationship with a male partner who has been surgically sterilized by vasectomy
- If a female of childbearing potential, have a negative serum pregnancy test
13. Screening clinical laboratory tests must be acceptable to the Investigator
 14. Screening ECG must be acceptable to the Investigator
 15. Compliance: must be willing to remain at the study center as required per protocol to complete all visit assessments

5.2 Exclusion Criteria

Subjects who meet any of the following criteria in relationship to Visit 1, unless otherwise stated, will be excluded from the study.

1. Oral corticosteroid use (any dose) within 4 weeks
2. Received any marketed (eg, omalizumab) or investigational biologic within 3 months or 5 half-lives, whichever is longer, or any other medication specifically prohibited by the protocol within the indicated exclusionary time periods ([Table 5-4](#) and [Table 5-5](#))
3. Current smokers, former smokers with >10 pack-years history, or former smokers who stopped smoking <6 months previously (including all forms of tobacco, e-cigarettes, and marijuana)
4. Life-threatening asthma as defined as a history of significant asthma episode(s) requiring intubation associated with hypercapnia, respiratory arrest, hypoxic seizures, or asthma-related syncopal episode(s)
5. Completed treatment for lower respiratory infection or asthma exacerbation within 4 weeks
6. Upper respiratory infection not resolved within 7 days
7. Hospitalizations for asthma within 3 months
8. Historical or current evidence of a clinically significant disease including, but not limited to: cardiovascular (eg, congestive heart failure, known aortic aneurysm, clinically significant cardiac arrhythmia, coronary heart disease), hepatic, renal, hematological, neurological, endocrine (eg, uncontrolled diabetes mellitus, uncontrolled thyroid disorder, Addison's disease, Cushing's syndrome), gastrointestinal (eg, poorly controlled peptic ulcer, gastroesophageal reflux disease), or pulmonary (eg, chronic bronchitis, emphysema, bronchiectasis with the need of treatment, cystic fibrosis, bronchopulmonary dysplasia, chronic obstructive pulmonary disease). Significant is defined as any disease that, in the opinion of the Investigator, would put the safety of the subject at risk through participation, or that could affect the efficacy or safety analysis if the disease/condition exacerbated during the study

9. Pacemaker or implantable cardioverter-defibrillator/cardiac resynchronization therapy/cardiac resynchronization therapy-defibrillator devices
10. Narrow angle glaucoma not adequately treated. All medications approved for control of intraocular pressures are allowed, including topical ophthalmic non-selective β -blockers
11. Symptomatic prostatic hypertrophy that in the opinion of the Investigator is clinically significant and not adequately controlled with appropriate therapy
Note: Subjects with a trans-urethral resection of prostate or full resection of the prostate within 6 months prior to Visit 1 are excluded from the study.
12. Bladder neck obstruction or urinary retention that is clinically significant in the opinion of the Investigator
13. Calculated creatinine clearance ≤ 30 mL/minute using the Chronic Kidney Disease Epidemiology Collaboration (CKD-EPI) formula for subjects >18 to 80 years of age or the Schwartz formula for subjects 12 to ≤ 18 years of age at Visit 1 and on repeat testing prior to Visit 4; where ≤ 18 years of age is defined as anyone less than 18 years up to and including their 18th birthday and >18 years of age is defined as 18 years +1 day and older
14. Abnormal liver function tests, defined as aspartate aminotransferase (AST), alanine aminotransferase (ALT), or total bilirubin (TBL) ≥ 1.5 times the upper limit of normal (ULN) at Visit 1 and on repeat testing prior to Visit 2 (Note: Chronic stable hepatitis B or C is acceptable)
15. Cancer not in complete remission for at least 5 years
Note: Subjects with squamous cell carcinoma of the skin, basal cell carcinoma of the skin, in situ carcinoma of the cervix, or localized prostate cancer are eligible if, in the opinion of the Investigator, the condition has been adequately worked up and clinically controlled and the subject's participation in the study would not represent a safety concern.
16. Hospitalized for psychiatric disorder or attempted suicide within 1 year
17. History of psychiatric disease, intellectual deficiency, poor motivation, or other conditions limiting informed consent validity
18. Hypersensitivity to β_2 -agonists, corticosteroids, anticholinergics, or any component of the investigational MDI, Spiriva Respimat (tiotropium), or ipratropium
19. Significant, in the opinion of the Investigator, abuse of alcohol or drugs
20. Unable to abstain from protocol-defined prohibited medications during Screening and Treatment Periods
21. Using any herbal products by inhalation or nebulizer within 2 weeks and does not agree to stop during the study duration
22. Received a live attenuated vaccination within 7 days
23. Study investigators, sub-investigators, coordinators, and their employees or immediate family members
24. Treatment with investigational study drug (or device) in another clinical study within the last 30 days or 5 half-lives, whichever is longer
25. Previously randomized in any PT001 study

5.3 Randomization Criteria

Each subject must meet the following criteria on the morning of Visit 4 to be randomized:

1. Subjects of childbearing potential only: have a negative urine pregnancy test prior to administration of the study drug
2. Received no asthma medication other than ICS/LABA (plus ipratropium, if previously receiving tiotropium at Visit 1) and Sponsor-provided albuterol from Visit 1 to Visit 4, except for allowable asthma and allergy medications defined in [Table 5-2](#) and [Table 5-3](#)
3. Fulfillment of at least 1 of the following conditions for ≥ 3 days over the 7 days immediately prior:
 - Daytime or nighttime symptom score ≥ 1
 - Rescue albuterol use
4. Pre-dose FEV₁ $>40\%$ and $<85\%$ of predicted normal value for subjects 18 to 80 years of age or $>40\%$ and $<90\%$ of predicted for subjects 12 to <18 years of age
5. Demonstrate acceptable MDI administration technique
6. Able to comply with study procedures, including compliance with eDiary completion (ie, $\geq 70\%$ subject completion of diary assessments in the last 7 days)
7. No upper respiratory infection, lower respiratory infection, or moderate or severe asthma exacerbation during the Screening Period
8. No clinically significant findings on baseline 24-hour Holter monitoring conducted between Visits 3 and 4 (See [Section 5.5](#))

5.4 Re-Screening Criteria

Subjects who have an upper respiratory tract infection during Screening may re-screen following resolution and completion of treatment for at least 2 weeks.

Subjects who have a lower respiratory tract infection during Screening may re-screen following resolution and completion of treatment for at least 4 weeks.

Subjects 18 to 80 years of age may re-screen one time if they were screen failed because they had an FEV₁ $\geq 80\%$ and $<85\%$ of predicted normal value at V1, V2 (if applicable), or V4.

Subjects who have been on a stable regimen of an ICS/LABA for at least 4 weeks may re-screen if they were screen failed because they were not on an ICS/LABA for at least 3 months prior to Visit 1.

5.5 Holter Monitoring Sub-Study Exclusion Criteria

Subjects with clinically significant abnormal findings during the baseline Holter monitor recording defined as (but not limited to) any of the following will be excluded from the full

study. Subjects unable to provide a minimum of 18 hours of acceptable quality recording in a 24-hour period after 2 attempts will be excluded from the Holter monitoring sub-study, but DO NOT need to be excluded from the full study:

1. Average HR \leq 40 bpm for any 1 hour
2. Second-degree atrioventricular block (Type 2) or third-degree atrioventricular block
3. Sinus pause of EITHER:
 - 2.5 seconds duration during daytime
 - 3.0 seconds duration during nighttime
4. Any episode of ventricular flutter and/or ventricular fibrillation
5. Any episode of non-sustained ventricular tachycardia (NSVT) with symptoms of hypotension or syncope or asymptomatic NSVT >15 ventricular premature beats in a row
6. Sustained ventricular tachycardia (>30 seconds in duration)
7. Five or more episodes of NSVT over 24 hours
8. Greater than 500 ventricular premature beats/hour

5.6 Subject Identification

All subjects who undergo screening procedures will be assigned a unique screening identification number at Visit 1. Only subjects continuing to meet inclusion/exclusion criteria and randomization criteria at Visit 4 will be assigned a unique subject randomization number. Randomization will be centralized with an Interactive Web Response System (IWRS).

5.7 Prior, Concomitant, and Prohibited Medications and Vaccinations

5.7.1 Prior Medications

All prescription and over-the-counter medications, as well as any herbal or vitamin supplements, taken by the subject within 30 days of Visit 1 should be recorded on the prior/concomitant medications electronic case report form (eCRF); indication, total daily dose, and route and dates of drug administration should be captured to the best of the subject's and site's ability.

Subjects eligible for this study are required to be on a stable regimen of an inhaled asthma maintenance therapy defined as an ICS/LABA for at least 4 weeks prior to Visit 1. The permitted total daily ICS dosage to qualify ICS usage for the 4 weeks prior to Visit 1 is defined in [Table 5-1](#). Subjects also receiving tiotropium 2.5 μ g QD for at least 4 weeks prior to Visit 1 may be included.

Table 5-1 Permitted ICS Dosages in Fixed-Dose Combination Products With LABA

Asthma Inhaled Corticosteroid	Total Daily Dose (µg/day)	Example Fixed-Dose Combination Products
Budesonide	320 to ≤640	Budesonide and formoterol fumarate dihydrate (Symbicort®)
Fluticasone furoate	100 to ≤200	Fluticasone furoate and vilanterol trifenate (Breo® Ellipta®)
Fluticasone propionate	176 to ≤1000	Fluticasone propionate and salmeterol xinafoate (Advair® or AirDuo™ RespiClick®)
Mometasone furoate	400 to ≤800	Mometasone furoate and formoterol fumarate dihydrate (Dulera®)

5.7.2 Concomitant Medications and Vaccinations

Any current ongoing medications, including over-the-counter medications, herbal supplements, and vaccinations, will be allowed provided they are not explicitly prohibited by the protocol (Table 5-4 or Table 5-5). All concomitant medications taken during the study will be recorded on the concomitant medications eCRF page with indication, total daily dose, route of administration, and dates of drug administration. Any additions, deletions, or changes in the dose of these medications while in the study should be entered in the eCRF. Subjects should also be instructed to contact the Investigator if they develop any illnesses, especially those requiring medicinal intervention.

5.7.2.1 Vaccinations

All subjects should be vaccinated with annual influenza vaccine per local policies, availability, and affordability (GINA 2017). If a subject has egg intolerance or refuses to be vaccinated, the vaccination may be omitted. The annual influenza vaccine can be given at Visit 1 or at any other visit throughout the study at the discretion of the Investigator; however, administration should occur after obtaining all requisite spirometry assessments for that specific test day. There should be at least 7 days between vaccination and subsequent spirometry assessments.

5.7.2.2 Allowed Medications

5.7.2.2.1 ASTHMA AND ALLERGY MEDICATIONS

Table 5-2 lists asthma and allergy medications that are allowed during the study as long as the subject does not take these medications for the specified time periods prior to Visit 2 and all subsequent in-clinic visits.

Table 5-2 Allowed Asthma Medications With Required Holding Periods Prior to Visit 2 and All Subsequent Visits

Allowed Medication	Minimum Holding Period
Sponsor-provided SABA ^a	6 hours
LABAs ^b	24 hours: indacaterol, olodaterol, vilanterol 12 hours: salmeterol, formoterol
Sponsor-provided ipratropium ^c	6 hours

Abbreviation: SAMA=short-acting muscarinic antagonist.

- ^a All other SABAs and SAMAs besides Sponsor-provided albuterol and ipratropium (as appropriate) must be discontinued at Visit 1 and may not be used throughout the remainder of the Screening and randomized Treatment Periods.
- ^b In combination with an ICS
- ^c This washout only applies to subjects who are switched from tiotropium at Visit 1 to ipratropium. The ipratropium will be discontinued at Visit 4 for the remainder of the randomized Treatment Period.

Table 5-3 lists asthma and allergy medications that are allowed as long as the subject has been on a stable dose for at least 4 weeks prior to Visit 1 and remains on a stable dose throughout the study.

Table 5-3 Allowed Asthma and Allergy Medications

Non-sedating long-acting antihistamines ^a
Allergen immunotherapy
Intranasal corticosteroids
Intranasal antihistamines or combination products of intranasal antihistamines/corticosteroids
Montelukast sodium ^b
Intranasal ipratropium bromide

- ^a Short-acting antihistamines (eg, diphenhydramine) are also permitted for use as needed, but not regularly.
- ^b Leukotriene modifiers other than montelukast sodium are prohibited within 7 days prior to Visit 2 and throughout the Screening and randomized Treatment Periods.

5.7.2.2.2 TREATMENT OF AN ASTHMA EXACERBATION

If a subject experiences an asthma exacerbation, they should continue dosing with study drug, if possible. During the randomized Treatment Period, asthma exacerbations should be treated at the discretion of the Investigator, taking into consideration that the use of certain medications are prohibited for use during the study in conjunction with study drug (see Section 5.7.3.1).

Definitions of a mild, moderate, and severe asthma exacerbation are provided in Section 7.1.3.1, as are the recommended treatments for moderate and severe asthma

exacerbations. New or increased dose ICS treatment is permitted for treatment of a **moderate** asthma exacerbation, to help avoid progression to a severe exacerbation; oral corticosteroids are permitted for treatment of a **severe** asthma exacerbation.

Details regarding the collection of data concerning asthma exacerbations are provided in Section 7.3.6.

5.7.2.2.3 MEDICAL MARIJUANA

Edible medical marijuana is not an exclusionary drug if used for medical purposes and there is no change in the dose or frequency of consumption during study participation. Subjects who use medical marijuana by smoking or vaping are excluded (see also Section 5.8.1).

5.7.3 Prohibited Medications and Washout Periods

5.7.3.1 Prohibited Asthma and Allergy Medications and Washout Periods

Specific prohibited asthma and allergy medications and their required washout periods prior to Visit 2 are displayed in Table 5-4. Minimum washout periods for oral, intravenous (IV), intramuscular (IM), and depot steroids are shown in Section 5.7.3.2.

Table 5-4 Prohibited Asthma and Allergy Medications and Required Washout Period Prior to Visit 2

Medication	Minimum Washout Period Prior to Visit 2
Tiotropium ^a	2 weeks
Oral β_2 -agonists	2 days
Theophylline	2 days
Cromoglycate	7 days
Nedocromil	7 days
Ketotifen ^b	7 days
Zileuton	7 days
SAMA and/or SABA other than Sponsor provided ^c	7 days
Monoclonal antibodies (eg, anti-immunoglobulin E, anti-interleukin-5)	3 months or 5 half-lives, whichever is longer

^a Subjects currently on a LAMA other than tiotropium are excluded from study participation.

^b Ketotifen eye drops are allowed; no washout required.

^c Administered as fixed or loose combinations.

5.7.3.2 Prohibited Non-Asthma and Non-Respiratory Medications and Washout Periods

Subjects requiring medications presented in Table 5-5 are prohibited from participating in this study. Subjects who recently discontinued use of these medications may be considered

for study enrollment provided they have met the minimum cessation period prior to Visit 1. These medications are prohibited throughout the course of the study. If subjects require any of the prohibited medications listed in Table 5-5, the Investigator should discuss with the Medical Monitor the suitability of the subject continuing study drug.

Note: The minimum washout period prior to Visit 1 for oral, IV, and IM steroids is 4 weeks, and for depot (intra-articular and intraocular) steroids is 12 weeks. Use of systemic corticosteroids (eg, oral, parenteral, intraocular, intra-articular) to treat conditions other than a severe asthma exacerbation is prohibited for the duration of the study, including both the Screening and randomized Treatment Periods.

Table 5-5 Prohibited Non-Asthma and Non-Respiratory Medications and Required Washout Period Prior to Visit 1

Class of Medication	Minimum Cessation Period Prior to Visit 1 and Prohibited Throughout the Study
Any drug with potential to significantly prolong the QT interval ^{a,b}	14 days or 5 half-lives, whichever is longer
Other investigational drugs	30 days or 5 half-lives, whichever is longer
Non-selective non-ocular β -blocking agents	7 days
Cardiac anti-arrhythmics (Class Ia, III)	7 days, unless amiodarone, then 3 months
Anticonvulsants for seizure disorder ^c	Allowed if stable dose for 12 months and free of seizures for 1 year
Antipsychotic drugs ^d	30 days
Tricyclic antidepressants ^d	14 days
Monoamine oxidase inhibitors	14 days
Anti-tumor necrosis factor α antibodies (eg, infliximab and any other members of this class of drugs)	30 days or 5 half-lives, whichever is longer
Monoclonal antibodies ^e	30 days or 5 half-lives, whichever is longer
Cytochrome P450 enzyme inhibitors (eg, systemic calcineurin inhibitors, systemic antifungal agents, cimetidine)	30 days
Protease inhibitors (eg, ritonavir)	30 days
Systemic anticholinergics ^f	7 days
Chinese complementary and alternative bronchodilatory medicines, ie, herbal therapies (eg, <i>Astragalus membranaceus</i> [huáng qí], <i>Panax ginseng</i> [ginseng products] and <i>Cordyceps sinensis</i> , <i>A. membranaceus</i> [ghost moth caterpillar fungus]) ^g	To be determined ^g

Note: Benzodiazepines are not exclusionary. Serotonin norepinephrine reuptake inhibitors and selective serotonin reuptake inhibitors are not excluded as long as the subject has been on a stable dose for at least 4 weeks prior to Visit 1 and throughout the Screening and randomized Treatment Periods, and the dose does not exceed the maximum recommended.

- ^a Subjects who are on medications that have the potential to prolong the QTc interval may be enrolled provided the dose has remained stable for at least 3 months prior to Visit 1, the subject meets all of the ECG inclusion criteria and none of the ECG exclusion criteria, and if, in the opinion of the Investigator, there are no safety concerns for the subject to participate in the study. Initiation of medications with the potential to significantly prolong the QT interval is prohibited throughout the Screening and randomized Treatment Periods.
- ^b Short courses of macrolide and quinolone antibiotics to treat infections are permitted.
- ^c Anticonvulsants for conditions other than seizures may be started and stopped at any time prior to the study and throughout the Screening and randomized Treatment Periods.
- ^d Antipsychotic agents and tricyclic antidepressants used for previously diagnosed underlying medical conditions are allowed if, in the opinion of the Investigator, there are no concerns regarding patient safety, and if the subject has been on a stable dose for at least 6 weeks.
- ^e Investigators should contact the Medical Monitor to determine the appropriateness and safety of continuing study drug in consultation with the Medical Monitor on a case-by-case basis (eg, Prolia® [denosumab] for osteoporosis, may be allowed after consultation).
- ^f If systemic anticholinergics are used for the treatment of irritable bowel syndrome or overactive bladder and the treatment has been constant for at least 1 month, they are allowed.
- ^g Requires case-by-case review by the Investigator to determine appropriate washout period, if needed.

5.8 Other Restrictions, Illicit Drugs, and Drugs of Abuse

5.8.1 Illicit Drugs or Drugs of Abuse

Illicit drugs or drugs of abuse will not be allowed from Visit 1 to the end of the follow-up telephone call or to whenever the subject withdraws from the study. If any illicit drugs or drugs of abuse are used by the subject during the study, the dates of use and the amount will be documented and the subject will be discontinued from randomized study drug and withdrawn from the study at the discretion of the Investigator.

Edible medical marijuana is not an exclusionary drug if used for medical purposes and there is no change in the dose or frequency of consumption during study participation (see also Section 5.7.2.2.3). Subjects who use medical marijuana by smoking or vaping are excluded.

5.8.2 Dietary Restrictions

Subjects must not ingest xanthine and/or xanthine analogue (caffeine)-containing foods or beverages or caffeine-containing medications for at least 6 hours prior to and for the duration of each in-clinic study visit. Examples of such products include coffee, tea, chocolate, and cola. Decaffeinated beverages are acceptable.

5.9 Reasons for Study Drug Discontinuation or Study Withdrawal

5.9.1 Reasons for Study Drug Discontinuation

Subjects who discontinue study drug should be encouraged to continue in the study and complete all study visits and procedures.

If a subject experiences either of the below, the subject must be discontinued from study drug:

- An asthma exacerbation requiring inpatient hospitalization
- More than 2 severe asthma exacerbations requiring oral corticosteroid treatment

If a subject experiences any of the changes of concern listed below, a repeat assessment should be obtained, and if confirmed, the subject must be discontinued from study drug:

- Calculated Fridericia-corrected QT interval (QTcF) of either >500 msec and a ≥ 30 msec change from pre-dose baseline value obtained at Visit 4 OR a ≥ 60 msec change from pre-dose baseline value obtained at Visit 4
- Hepatic impairment, defined as an AST, ALT, or TBL concentration $\geq 3 \times \text{ULN}$

If a subject experiences any of the following changes of concern, a repeat assessment should be obtained, and if confirmed, the Investigator needs to determine the suitability of continuing the subject on study drug:

- A HR >120 bpm and in which there is an increase of >40 bpm from the pre-dose baseline value at Visit 4
- A systolic blood pressure (SBP) >160 mmHg and an increase of >40 mmHg from the pre-dose baseline value at Visit 4
- Either a decrease in creatinine clearance to a value ≤ 30 mL/minute using the CKD-EPI formula for subjects >18 to 80 years of age or the Schwartz formula for subjects 12 to ≤ 18 years of age at Visit 1 (where ≤ 18 years of age is defined as anyone less than 18 years up to and including their 18th birthday and >18 years of age is defined as 18 years +1 day and older) OR a clinically relevant change from pre-dose baseline obtained at Visit 4 as determined by the Investigator

Procedures for study drug discontinuation and study withdrawal are provided in Section 8.9.

5.9.2 Reasons for Study Withdrawal

If a subject becomes pregnant during the course of the study, she will discontinue study drug, and must be withdrawn from the study and followed until delivery or final outcome (see Section 7.3.12 for additional procedures).

Subjects may be withdrawn from the study at their own request or upon the request of the Investigator or the Sponsor at any time and for any reason (see Section 8.9 for additional procedures).

6 CLINICAL SUPPLY LABELING, PACKAGING, STORAGE, DISPENSING, AND RETURN

Study personnel will have access to an IWRS to allocate subjects, assign study-related medication to subjects, and manage the distribution of clinical supplies. Each person accessing the IWRS system will be assigned a unique personal identification number (PIN) to use for their access. The assigned PIN must not be shared with anyone, even another colleague involved with the study.

Clinical supplies will be packaged according to a component schedule generated by the Sponsor or their designee. Subjects receiving tiotropium prior to Visit 1 will be supplied ipratropium in an open-label fashion during the Screening Period. Study drug for all treatments other than Spiriva Respimat will be packaged to support enrollment of the study in a blinded fashion for the 24-week Treatment Period; treatment with Spiriva Respimat will be open-label.

The study drug and other medications provided by the Sponsor are described in Section 6.1 (randomized study drugs) and Section 6.2 (other medications). Medications to treat asthma exacerbations or other AEs will not be provided by the Sponsor.

6.1 Description of Study Drugs

In this protocol, “study drug” refers to an active ingredient or placebo being tested or used as a reference in the study. Study drugs used in this study are described in [Table 6-1](#).

Subjects meeting all randomization criteria (Section 5.3) will be randomized at Visit 4 to receive study drug QD (Spiriva) or BID (GP MDI or Placebo MDI) during the randomized Treatment Period. Instructions for reading the dose indicator for the GP MDI and Placebo MDI and for priming, use, and cleaning of the GP MDI and Placebo MDI are provided in [Appendix 4](#) and [Appendix 5](#), respectively. Instructions for the priming, use, and cleaning of the Spiriva Respimat are provided in [Appendix 6](#).

Table 6-1 Randomized Study Drugs

Product Name and Dose	Product Strength	Manufacturer	Dosage Form/ Fill Count	Administration
GP MDI 28.8 µg	GP MDI 14.4 µg per actuation	Pearl	MDI/ 120 inhalations	Taken as 2 inhalations BID
GP MDI 14.4 µg	GP MDI 7.2 µg per actuation	Pearl	MDI/ 120 inhalations	Taken as 2 inhalations BID
GP MDI 7.2 µg	GP MDI 3.6 µg per actuation	Pearl	MDI/ 120 inhalations	Taken as 2 inhalations BID
Placebo MDI ^a	No active ingredient	Pearl	MDI/ 120 inhalations	Taken as 2 inhalations BID
Spiriva Respimat 2.5 µg ^b	tiotropium 1.25 µg per actuation ^b	Boehringer Ingelheim Pharmaceuticals, Inc.	IS metered/ 60 inhalations	Taken as 2 inhalations QD

Abbreviation: IS=inhalation spray; MDI=metered dose inhaler.

Note: All study drugs will be administered by oral inhalation.

^a All Placebo MDIs are manufactured by the Sponsor in the image of the active test product.

^b Each actuation contains 1.25 µg tiotropium corresponding to 1.562 µg of tiotropium bromide monohydrate.

6.2 Other Sponsor-Provided Medications Used in the Study

Other Sponsor-provided medications used open-label during the study are shown in [Table 6-2](#). These medications will be commercial MDIs with dose counters and manufacturer's instructions for use. Instructions for use of the albuterol and ipratropium MDIs are provided in [Appendix 7](#) and [Appendix 8](#), respectively.

Table 6-2 Other Sponsor-Provided Study Medications

Product Name and Dose	Product Strength	Dosage Form/ Fill Count	Administration
Albuterol sulfate inhalation aerosol (Ventolin [®] HFA)	albuterol sulfate 90 µg/actuation ^a	MDI/ 60 or 200 actuations	Taken as directed for reversibility testing (Visits 1 and/or 2) ^b and as rescue during the Screening and randomized Treatment Periods
Ipratropium bromide inhalation aerosol (Atrovent [®] HFA) ^c	ipratropium bromide 17 µg/actuation	MDI/ 200 actuations	Taken during the Screening Period as 2 inhalations QID (selected subjects ^c) and as 4 inhalations for reversibility testing at Visit 3 (all subjects)

^a Each inhalation contains 108 µg albuterol sulfate corresponding to 90 µg albuterol base per actuation.

^b Reversibility to albuterol is a requirement that may be met at either Visit 1 or 2.

^c Only for subjects receiving tiotropium 2.5 mg QD for at least 4 weeks prior to Visit 1.

6.3 Packaging and Labeling

6.3.1 Primary Packaging and Labeling

All clinical trial supplies will be packaged by the Sponsor.

Blinded study drug (GP MDI and Placebo MDI) will be packaged in a box and labeled with a single label. Inside the box will be a labeled actuator and a labeled foil pouch containing the MDI canister of study drug.

Open-label medications (albuterol, ipratropium, and Spiriva Respimat) will be provided as individually labeled inhalers with a single label on the actuator.

Labels will be printed with black ink and may include the following text:

Lot # (Packaging Lot Trace ID) Space for entry of screening # Component ID # Space for entry of randomization # Fill count and dosage form Visit # (Space for entry of Interval ID)	Storage Conditions Protocol # Country regulatory requirements Sponsor address
--	--

Abbreviations: #=number; ID=identification

6.3.2 Secondary Packaging and Labeling

All clinical trial supplies will be packaged in individual visit boxes containing 1 MDI each. Box configuration is subject to change as a result of packaging constraints.

Each box will be labeled with a 2-part label printed with black ink and may include the following text:

Packaging Lot ID # Space for entry of screening # Component ID # Space for entry of randomization # Kit contents (1 MDI) Space for entry of Interval ID Re-evaluation/Expiration date (if applicable)	Dosing instructions (if applicable) Storage conditions Compound ID - Protocol # Country regulatory requirements Sponsor address (if applicable)
---	---

Abbreviations: #=number; ID=identification

6.4 Storage Requirements

All clinical drug supplies should be kept in a locked cabinet or room with limited access. The temperature of the site's storage area for study drugs must be monitored by site staff for temperature ranges consistent with those specified for each product as outlined below. Documentation of temperature monitoring should be maintained at the site and available for review.

- All clinical drug supplies contain contents under pressure. Do not use or store near heat or open flame. Exposure to temperatures above 49°C (120°F) may cause bursting. Never throw clinical drug canisters into a fire or incinerator. Avoid spraying in eyes.
- Albuterol MDI (Ventolin HFA) should be stored at room temperature between 20°C and 25°C (68°F-77°F); excursions permitted from 15°C to 30°C (59°F-86°F). Store the inhaler with the mouthpiece down. For best results, the inhaler should be at room temperature before use. SHAKE WELL BEFORE EACH SPRAY.
- GP MDI and Placebo MDI should be stored below 25°C (77°F); excursions permitted up to 30°C (86°F). Do not freeze.
- Ipratropium inhalers (Atrovent HFA) should be stored at 25°C (77°F); excursions permitted to 15°C to 30°C (59°F to 86°F). For optimal results, the canister should be at room temperature before use.
- Spiriva Respimat inhaler (tiotropium) should be stored at 25°C (77°F); excursions permitted to 15°C to 30°C (59°F to 86°F). Avoid freezing.

6.5 Instructions for Dispensing and Preparation of Study Drugs for Administration

Before dispensing the study drug to the subject, authorized study staff must confirm the identifier given by the IWRS and the component identification number written on the label are the same. To document dispensing of the study drug, the authorized study staff will write the subject number and treatment visit number on each of the 2-part labels and affix the ‘tear off’ part of the label onto the IWRS confirmation report.

All GP MDIs and Placebo MDIs must be primed before the first use. To prime the inhaler, gently shake the inhaler for 5 to 10 seconds and then spray once into the air away from yourself and others. Wait approximately 30 seconds and repeat the process 3 more times (see [Appendix 5](#) for complete instructions). Shaking and priming the inhaler fills a chamber inside the canister with the correct dose and mix of medication so that the inhaler is ready to use. Priming should occur in a separate room from the subject treatment area.

Similarly, the Spiriva Respimat inhaler must be primed before the first use. To prime the inhaler, in brief, point the inhaler toward the ground and press the dose-release button. If a mist is seen, repeat for 3 more actuations; if a mist is not seen, follow the manufacturer’s instructions (see [Appendix 6](#) for complete instructions).

Once the inhalation device is primed, the first dose (2 puffs) of study drug should be taken by the subject in the clinic under site personnel supervision. The date and time of the second puff should be recorded as the time of dose administration (ie, in iDataFax for in-clinic doses and in the e-Diary for at-home dosing). Subjects should be instructed to inhale 2 puffs in the morning and, unless randomized to Spiriva Respimat, 2 puffs in the evening approximately 12 hours apart. The timing of the morning administration should match ± 1 hour of in-clinic study drug administration.

Refer to [Appendix 5](#) for additional instructions on the administration and cleaning of the GP MDI and Placebo MDI, and to [Appendix 6](#) for instructions on the administration and cleaning of the Spiriva Respimat inhaler. Instructions for the albuterol MDI and ipratropium inhaler are provided in [Appendix 7](#) and [Appendix 8](#), respectively.

6.6 Emergency Unblinding

The Investigator or designee may unblind a subject's treatment assignment **only in the case of an emergency**, when knowledge of the study treatment is essential for the appropriate clinical management or welfare of the subject.

Emergency unblinding of study drug, for a given subject, must be done utilizing the IWRS as a study treatment disclosure envelope will not be provided with the clinical supplies.

Whenever possible, the Investigator should first discuss options with the Sponsor's Medical Monitor or other appropriate study personnel from the Sponsor **before** unblinding the subject's treatment assignment. If this is impractical, the Investigator must notify the Sponsor as soon as possible, but without revealing the treatment assignment of the unblinded subject, unless that information is important for the safety of other subjects currently enrolled in the study.

If the Investigator contacts IWRS to unblind a subject, s/he must provide the requested subject identifying information and confirm the necessity to unblind treatment. The date and reason for the unblinding must be recorded in the appropriate eCRF.

6.7 Drug Accountability/Return of Clinical Supplies

Under no circumstances will the Investigator(s) allow the study drug to be used other than as directed by this protocol.

Investigational clinical supplies must be received by a designated person at the study site, handled and stored safely and properly, and kept in a secure location to which only the Investigator and designated study personnel have access. Clinical supplies should be dispensed only in accordance with the protocol.

The Investigator or designee is responsible for keeping accurate records of the clinical supplies received from the Sponsor, the amount dispensed to and returned by the subject, and the amount remaining at the conclusion of the study. Study drug should be handled in accordance with Good Pharmacy Practices (eg, gloves should always be worn by study personnel if directly handling study drug that is returned). The Sponsor's Medical Monitor or designee should be contacted with any questions concerning investigational products where special or protective handling is indicated. At the end of the study, all clinical supplies including partial and empty containers must be returned as directed by the Sponsor.

Sites should check with the Sponsor representative for appropriate documentation that needs to be completed for drug accountability.

The Investigator or designated study personnel should not open individual clinical supply containers until all pre-dose assessments have been completed and the subject is eligible to be randomized/continue with the study. Any deviation from this must be discussed with the Sponsor's Medical Monitor or designee.

For each subject, all used study drug materials will be collected. Used subject supplies will be kept at room temperature in a secure and locked cabinet until returned to the Sponsor or designee. Used study drug must be stored separately from unused study drug.

All product complaints (including device malfunctions) must be reported to the Sponsor or the Sponsor's representative using the Product Complaints Form provided in each site's regulatory binder. The Sponsor or their representatives will contact the site to evaluate the nature of the complaint and determine if further action is needed.

7 STUDY PROCEDURES

A schedule of events for all study assessments is provided in [Table 8-1](#). A detailed visit schedule for all pre- and post-dose assessments is described in [Table 8-2](#). A summary of 24-hour Holter monitoring sub-study procedures is in [Table 8-3](#).

7.1 Efficacy Assessments

7.1.1 Pulmonary Function Tests

7.1.1.1 Spirometry Standardization

All pulmonary function tests (PFTs) including FEV₁, forced vital capacity, and forced expiratory flow in the midpoint as defined in ATS/ERS guidelines will be performed in accordance with ATS criteria ([Appendix 2](#); Miller 2005) and will be assessed using a spirometer that meets or exceeds minimum performance recommendations of the ATS ([Appendix 3](#)).

To standardize spirometry, all sites will be provided with identical spirometry systems [REDACTED] with customized, study-specific software. Every effort will be made to provide all sites with standardized spirometry equipment. The volume accuracy of the spirometer is to be checked daily with appropriate documentation in a calibration log prior to the conduct of PFTs on each test day.

The volume accuracy of the spirometer is checked using a 3 L syringe across 3 flow ranges (ie, low, medium, and high flows), with temperature and barometric pressure correction. The calibration syringe must meet ATS specifications and not be used beyond the expiry date. Required accuracy is $\pm 3\%$ (ie, 3.09 L to 2.91 L; ATS/ERS). The results will be printed and maintained in a calibration log, which will be monitored for compliance during the monitoring visits (see [Appendix 2](#)).

All study staff responsible for performing PFTs will receive standardized training at the Investigator Meeting. All technicians are required to demonstrate proficiency in the use of the equipment and the ability to perform technically acceptable PFTs (ATS criteria) prior to performing PFTs on study subjects (Miller 2005). After each test is performed, the spirometry software will provide immediate feedback to the technician indicating whether the effort meets ATS acceptability and repeatability standards (Miller 2005). All PFTs will be stored electronically. After completion of testing, the study staff will electronically transmit the spirometry measurements for centralized quality assurance review [REDACTED]. Feedback on the quality of the measurements will be provided to the investigational site and to the Sponsor or designee for central data management.

As spirometry results are primary and secondary efficacy endpoints for this study, it is important for the medication withholding conventions and timing of spirometry to be consistently managed throughout the study (Section 8.1).

7.1.1.2 Spirometry Schedule

Spirometry collection is briefly outlined below. For exact spirometry collection and specifications, please refer to [Table 8-1](#) and [Section 8](#).

- Visit 1:
 - Spirometry, including reversibility to albuterol, will be performed at Visit 1 only if the subject did not take their morning doses of inhaled asthma maintenance medications and if albuterol was not administered within 6 hours. If the subject has not withheld their dose(s) of regular asthma medications ([Section 8.1](#)) or albuterol, Visit 1 should be rescheduled no sooner than the following day.
 - Spirometry will be conducted at 60 and 30 minutes prior to bronchodilator (albuterol) administration and 30 minutes post-bronchodilator ([Section 7.1.1.3](#)). If subjects are not reversible to albuterol at 30 minutes post-dose, the post-dose PFTs can be repeated at 60 minutes post-dose.
 - The average of the 2 pre-bronchodilator FEV₁ values will be calculated to determine if the subject meets the inclusion criterion (ie, FEV₁ >40% and <85% of predicted normal value for subjects 18 to 80 years of age or FEV₁ >40% and <90% of predicted normal value for subjects 12 to <18 years of age).
 - FEV₁ repeatability must be demonstrated at one of the pre-dose measurements.
- Visit 2:
 - Spirometry will only be conducted in those subjects who did not demonstrate reversibility to albuterol at Visit 1.
 - Subjects who did not meet albuterol reversibility criteria at Visit 1 must meet these criteria at Visit 2.
 - When spirometry is conducted at Visit 2, the procedures will be the same as those described above for Visit 1 (eg, FEV₁ inclusion criterion must be met).
- Visit 3: spirometry will be conducted 60 and 30 minutes prior to ipratropium administration and 30 minutes post-ipratropium ([Section 7.1.1.3](#)).
- At Visits 4, 7, and 10/Final Visit or the Treatment Discontinuation Visit: spirometry will be conducted 60 minutes and 30 minutes prior to study drug and ICS/LABA administration and 15 minutes, 30 minutes, and 1, 2, and 4 hours post-dosing with study drug and ICS/LABA (if a subject discontinues taking study drug but agrees to continue in the study and complete all remaining study visits, the subject's usual inhaled asthma maintenance medication(s) will be administered for spirometry testing instead of study drug). At Visit 4, the average of the 2 pre-dose FEV₁ values will be calculated to determine if the subject meets the inclusion criterion.
- At Visits 5, 6, 8, and 9: spirometry will be conducted 60 minutes and 30 minutes prior to study drug and ICS/LABA administration.

Subjects will be required to return to the clinic at approximately the same time of day for all treatment visits. All in-clinic dosing must occur prior to 10 am with consistent in-clinic dose

timing throughout the randomized Treatment Period; visits must be planned accordingly (Section 8.1). The subjects will be required to remain at the clinic until completion of all protocol-defined assessments.

7.1.1.3 Reversibility to Albuterol and Ipratropium

Reversibility to albuterol will be evaluated for subject qualification purposes, and reversibility criteria must be met at either Visit 1 or Visit 2 (Section 5.1). If reversibility criteria are met at Visit 1, reversibility testing will not be repeated at Visit 2. If reversibility criteria are not met at Visit 1, subjects may continue to Visit 2; however, reversibility criteria must be met at Visit 1 or Visit 2 to continue to Visit 3.

Reversibility to ipratropium will be evaluated at Visit 3 for characterization and randomization stratification purposes.

The procedures for determining reversibility to albuterol and ipratropium are as follows:

1. Determine if morning doses of all maintenance asthma medications were withheld and that short-acting bronchodilators were not administered within 6 hours of testing
2. Perform prebronchodilator PFTs at 60 and 30 minutes prior to administration of bronchodilator
3. Administer 4 puffs of albuterol (Visit 1 and, if needed, Visit 2) or 4 puffs ipratropium (Visit 3).
4. Perform postbronchodilator PFTs 30 minutes after the administration of either albuterol or ipratropium (as appropriate per visit). If subjects are not reversible to albuterol at 30 minutes, the post-dose PFT can be repeated at 60 minutes post-dose. Repeat spirometry at 60 minutes post-dose is not necessary for reversibility testing to ipratropium.

Reversibility will be a comparison of the average best FEV₁ effort obtained at 60 and 30 minutes prebronchodilator to the best FEV₁ effort obtained at 30 minutes (or up to 60 minutes, if repeated for albuterol) postbronchodilator following administration of either albuterol or ipratropium. A subject is considered reversible to albuterol if the improvement in FEV₁ at 30 minutes (or up to 60 minutes) post-albuterol is $\geq 12\%$ and ≥ 200 mL.

7.1.2 Subject's eDiary Data Collection

At Visit 1, subjects will be trained on and receive their eDiary. Prior to issuing the eDiary to the subject, site personnel are responsible for programming the eDiary and training subjects on its use. Subjects will enter the following information into the eDiary BID beginning with Visit 1 and for the duration of the study during both Screening and Treatment Periods: daytime and nighttime asthma symptom scores, and use of rescue albuterol. During the Screening Period, time of ICS/LABA administration will also be entered (this will be QD for ICS/LABAs that are only administered QD and BID otherwise); ipratropium use, if applicable, will be recorded as a concomitant medication. During the Treatment Period, time

of study drug administration will also be entered; time of ICS/LABA administration will then be recorded as a concomitant medication.

7.1.2.1 eDiary Compliance Requirement

Between Visits 1 and 4, subjects will be required to demonstrate acceptable eDiary collections and compliance in order to be eligible for randomization. Subject participation may be terminated at any time during the study for the following reasons:

- Subjects who are unable to meet the compliance requirement ($\geq 70\%$ subject completion of eDiary assessments) in the 7 days prior to Visit 4 will be considered a screen failure
- Chronic failure in the judgment of the Investigator (eg. noncompliance with the eDiary), despite documentation at the site of repeated efforts to reinforce compliance. As defined for this study, compliance requires $\geq 70\%$ subject completion of eDiary assessments for the duration of the study. The Sponsor may also instruct a site to discontinue a subject based on consistent noncompliance.

7.1.2.2 Rescue Medication Use

Use of rescue medication will be recorded in the eDiary each morning (reflecting nighttime albuterol use) and each evening (reflecting daytime albuterol use). The subject will record the total number of “puffs” of albuterol used over the time period as the number of actuations on the canister. For example, when rescue medication is required and 2 actuations are inhaled, this should be recorded as 2 “puffs.” If the subject requires 4 actuations, this should be recorded as 4 “puffs.”

7.1.2.3 PEFr

The PEFr is to be assessed using the Sponsor-provided PEFr meter, which will be paired with the eDiary via Bluetooth. Subjects will be dispensed and trained on the device at Visit 1. The eDiary will remind the subject BID when it is time to obtain their peak flow. Once the subject has completed the peak flow assessment, the data will be automatically transmitted from the PEFr to the eDiary. The best (highest) of 3 PEFr efforts BID will be captured in the eDiary.

Subjects will complete the PEFr maneuver at home once in the morning and once in the evening before dosing with ICS/LABA (and ipratropium, if applicable) during the Screening Period, and once in the morning and once in the evening before dosing with study drug and ICS/LABA during the Treatment Period. In addition, PEFr should be measured before use of rescue albuterol.

On the morning of all clinic visits, PEFr will be assessed at home prior to coming to the clinic. Subjects do not need to bring their peak flow meter to clinic visits, except to their final visit.

At Visit 4, a PEFR stability limit will be automatically calculated by the eDiary. The stability limit is defined as the average of the available morning PEFR eDiary recordings during at least 4 of the last 7 days before Visit 4 (ie, the baseline PEFR), multiplied by 0.8. The PEFR stability limit will be used to help identify moderate asthma exacerbation as described in Section 7.1.3.

7.1.2.4 Asthma Symptoms

The subject will record their asthma symptom scores in the eDiary each morning (reflecting nighttime symptoms) and each evening (reflecting daytime symptoms). This symptom assessment should occur before determining PEFR and before administration of any medications during the Screening Period or randomized Treatment Period.

Subjects will assess the symptoms of cough, wheeze, shortness of breath, and chest tightness and enter a single score that is inclusive of all symptoms for their daytime and nighttime symptom scores. Symptom scores will be used to help identify moderate asthma exacerbations as described in Section 7.1.3.

The following symptoms will be assessed:

Daytime Symptom Score (determined in the evening)

- 0=No symptoms during the day
- 1=Symptoms for 1 short period during the day
- 2=Symptoms for 2 or more short periods during the day
- 3=Symptoms for most of the day that did not affect my normal daily activities
- 4=Symptoms for most of the day that did affect my normal daily activities
- 5=Symptoms so severe that I could not go to work or perform normal daily activities

Nighttime Symptom Score (determined in the morning)

- 0=No symptoms during the night
- 1=Symptoms causing me to wake once (or wake early)
- 2=Symptoms causing me to wake twice or more (including waking early)
- 3=Symptoms causing me to be awake for most of the night
- 4=Symptoms so severe that I did not sleep at all

On clinic visit mornings, the nighttime symptom score will be determined and recorded at home prior to the clinic visit.

7.1.2.5 Study Drug and Other Study Medication Compliance

During the Screening Period, subjects will record the times of ICS/LABA dosing in the eDiary for practice. Rescue medication (albuterol) use will also be recorded as described in Section 7.1.2.2.

During the Treatment Period, subjects will record the times of study drug dosing (morning and evening for BID treatments, morning only for the QD treatment) in the eDiary, except on the mornings of in-clinic dosing.

ICS/LABA dosing during the Screening Period and during the Treatment Period will be recorded as concomitant medications.

Study drug compliance will be checked at all visits. Any issues identified will be documented in the appropriate study file and reinstruction will be completed as necessary.

7.1.2.6 Symptom Worsening Assessment and eDiary Alert System

The eDiary will be programmed to monitor for signs of a potential asthma exacerbation by monitoring decreases from baseline in morning or evening PEFr, increases from baseline in the number of puffs of albuterol used per day, and/or increases in daytime or nighttime asthma symptom scores (Section 7.1.3). If any of these parameters meet the pre-defined thresholds for a moderate asthma exacerbation (Table 7-1), the eDiary will generate an alert to the subject and the clinical site. This alert is intended to generate a contact between the subject and the Investigator to assess the status of the subject's asthma.

7.1.3 Asthma Exacerbations

7.1.3.1 Definitions and Treatments

The definitions of mild, moderate, and severe asthma exacerbations to be used in this study are shown in Table 7-1. These definitions are based on the ATS/ERS Statement "Asthma Control and Exacerbations, Standardizing Endpoints for Clinical Asthma Trials and Clinical Practice" (Reddel 2009).

Table 7-1 Definition and Severity of Asthma Exacerbations

Severity of Asthma Exacerbation	Definition	Criteria for Study Drug Discontinuation ^c
Severe ^a	Use of systemic corticosteroids (tablets, suspension, or injection) for at least 3 days OR a hospitalization or ER visit because of asthma	There are 2 criteria for discontinuing study drug based on asthma exacerbations (Section 5.9.1): <ul style="list-style-type: none"> • Inpatient hospitalization • Requirement for >2 courses of oral corticosteroids to treat an exacerbation during the course of the study
Moderate ^b	A deterioration of asthma requiring a new or increased dose of ICS for at least 3 days. Deterioration of asthma is defined by the occurrence of 1 or more of the following for ≥ 2 consecutive days: <ul style="list-style-type: none"> • PEFR: a decline of $\geq 20\%$ from baseline (see Section 7.1.2.3 for baseline PEFR stability limit calculation) • Rescue albuterol use: >4 puffs/day and $\geq 2 \times$ baseline • Symptoms: nighttime score that is >baseline and ≥ 2 OR a daytime score that is >baseline and ≥ 3 	
Mild	A deterioration of asthma (as defined above) <ul style="list-style-type: none"> • Not requiring treatment OR • Requiring treatment with a systemic corticosteroid or a new or increased dose of ICS for <3 days 	

Abbreviation: ER=emergency room.

- ^a Subjects who have died because of asthma will be considered to have had a severe asthma exacerbation regardless of whether they received systemic corticosteroids or were hospitalized.
- ^b Will be captured via the eDiary.
- ^c For subjects who discontinue study drug, the Investigator will place subjects on appropriate asthma medications and the subjects will be encouraged to stay in the study and complete all remaining study visits and procedures.

In cases where the subject meets the criteria for a moderate or severe asthma exacerbation, the Investigator or designee will enter the information into the eCRF on the asthma exacerbation page (refer to Section 7.1.3.3). A mild exacerbation will be captured by the eDiary.

The recommended treatment for a **moderate asthma exacerbation** is a short course (5-7 days) of an increased dose of ICS or an additional ICS as outlined below, to help avoid progression to a severe exacerbation:

- Budesonide 400 µg BID for 5 to 7 days

Note: Each actuation of Pulmicort Turbuhaler 200 µg delivers 160 µg budesonide from the mouthpiece, which is the same amount as delivered by an actuation of Pulmicort Flexhaler 180 µg.

For an individual subject, the same increased dose of ICS or additional ICS should be used throughout the study when possible.

The recommended (GINA 2017) treatment for a **severe asthma exacerbation** is a short course of oral corticosteroids as outlined below:

- Prednisolone (1 mg/kg/day up to 50 mg for adults and adolescents) QD (preferably in the morning) for 5 to 7 days
- Tapering the prednisolone dose is not needed if the treatment has been given for <2 weeks

Additional information about treatment of asthma exacerbations is provided in Section [5.7.2.2.2](#).

7.1.3.2 Onset and Duration of Asthma Exacerbations

For a **severe** asthma exacerbation, the start date is defined as the start date of prescribed treatment with a systemic corticosteroid or the date of ER visit or hospitalization for asthma. The stop date is defined as the last day on which systemic corticosteroids were used, or the discharge date from the ER or hospital for asthma, whichever is later.

For a **moderate** asthma exacerbation, the start date is defined as the first day of the increased dose of ICS or new ICS treatment (for example, adding inhaled budesonide) and the end date is defined as the last day of this treatment.

For a **mild** asthma exacerbation, the start date is defined as the first day of 2 consecutive days of deterioration and the end date is defined as the first day the subject no longer meets the deterioration criteria OR the last day of treatment, whichever is later. Treatment must be for less than 3 days to meet the criteria for a mild exacerbation.

In order to ensure that the same event is not counted twice, consecutive exacerbations with start and stop dates ≤ 7 days apart will be considered to be the same event of the highest severity. Any exceptions and clarifications to this rule will be provided in detail in the statistical analysis plan.

7.1.3.3 Approach for Capturing Asthma Exacerbations

Asthma exacerbations occurring prior to Visit 1 will be considered part of the subject's medical history and will be captured in the medical history eCRF.

All moderate and severe asthma exacerbations occurring after Visit 4 must be captured on the asthma exacerbation eCRF page. Mild exacerbations will be identified and captured by the eDiary alert system.

Asthma exacerbations will be considered expected study endpoints and will not be reported as AEs unless they meet the criteria for a serious adverse event (SAE). The start date for an SAE of severe asthma exacerbation should be the start date of systemic corticosteroids or the date of ER visit or hospitalization for asthma as stated in Section 7.1.3.2.

7.1.4 Subject Questionnaires

Subject questionnaires (ACQ and the AQLQ +12) will be completed on site utilizing study-supplied electronic questionnaire devices (not the subject's eDiary) at specified visits throughout the study.

7.1.4.1 ACQ

The ACQ will be completed at Visits 2 and 4 through 10/Final Visit, or if the subject withdraws consent/discontinues study drug, at the Treatment Discontinuation or Study Withdrawal Visit, before any other study procedures are performed.

The ACQ ([Appendix 9](#); Juniper 1999a) was developed to measure asthma control and has been fully validated for use in adults and in children 6 to 17 years of age. International guidelines for the treatment of asthma have identified that the primary clinical goal of asthma management is to optimize asthma control (minimization of symptoms, activity limitation, bronchoconstriction, and rescue bronchodilator use) and thus reduce the risk of life-threatening exacerbations and long-term morbidity. The ACQ was developed to meet these criteria by measuring both the adequacy of asthma control and change in asthma control, which occurs either spontaneously or as a result of treatment.

The ACQ, comprising 7 questions, is completed in the clinic and requires subjects to recall their experiences during the previous week (7 days) prior to the study visit. The ACQ-5, -6, and -7 (questions 1-5, 1-6, and 1-7, respectively) have all been validated. The ACQ-5 measures 5 symptoms (woken at night by symptoms, wake in the morning with symptoms, limitation of daily activities, shortness of breath, and wheeze); the ACQ-6 is these symptom measurements plus daily rescue medication use as recalled by the subject; and the ACQ-7 is the ACQ-6 plus airway caliber as measured by pre-bronchodilator FEV₁ percent predicted. Each question is scored on a 7-point scale (generally, 0=no impairment, 6=maximum impairment), the questions are equally weighted, and the ACQ score is the mean of the item responses and therefore ranges from 0 (totally controlled) to 6 (severely uncontrolled).

7.1.4.2 AQLQ +12

The AQLQ +12 will be completed at Visits 4 through 10/Final Visit, or at the Treatment Discontinuation or Study Withdrawal Visit, after the ACQ and before any other study procedures are performed.

The AQLQ +12 is a 32-item validated subject-administered questionnaire that was developed to measure the functional problems (physical, emotional, social and occupational) that are most troublesome to adults (≥ 18 years of age) and adolescents (12 to 17 years of age) with asthma (Juniper 2005, Juniper 1999b, Juniper 1994, Juniper 1993, Juniper 1992). The 32 questions in the AQLQ +12 are in 4 domains (symptoms, activity limitation, emotional function, and environmental stimuli). All 4 domains contain standard specific questions relating to each domain.

Subjects are asked to think about how they have been during the previous 2 weeks and to respond to each of the 32 questions on a 7-point scale (7=no impairment to 1=severe impairment). The overall AQLQ +12 score is the mean of all 32 responses and the individual domain scores are the means of the items in those domains. A change in score of 0.5 on the 7-point scale is the smallest change that can be considered clinically important, known as the minimal clinically important difference. Additional information about the AQLQ +12 is provided in [Appendix 10](#).

7.1.5 F_{ENO}

The F_{ENO} will be collected at Visits 2, 4, 5, 7, and 10/Final Visit, or at the Treatment Discontinuation or Study Withdrawal Visit, prior to spirometry. The procedure is described in [Appendix 11](#).

Measurement of F_{ENO} is a noninvasive and established clinical biomarker for airway inflammation that is recommended by the ATS to monitor eosinophilic airway inflammation in subjects with asthma (Dweik 2011). Each site will be provided with a F_{ENO} device (Niox Vero[®] [Circassia Pharmaceuticals Inc., Chicago, Illinois, US]) and all required accessories (eg, test kits) and receive training on its use and care ([Appendix 11](#)). Clinically meaningful increases and decreases in F_{ENO} are defined in Section 9.5.3.9.

7.2 Safety Assessments

Safety assessments for this study are AEs, physical examinations, vital signs, 12-lead ECGs, 24-hour Holter monitoring, and clinical laboratory tests.

7.2.1 Medical/Surgical/Asthma Exacerbation History and Physical Examination

Medical history will be collected at Visit 1 and updated during the Screening Period, if necessary. The number of asthma exacerbations requiring systemic corticosteroids, emergency room visits, and/or hospitalizations within the previous 12 months will be collected at Visit 1.

A complete physical examination will be performed at Visits 1 and 10/Final Visit. The complete physical examination will include the following:

- Weight, general appearance, skin, head, eyes, ears, nose, throat, neck (including thyroid), lymph nodes, chest, heart, abdomen, extremities, and nervous system

- Height will be measured at Visit 1 for subjects who have had their 18th birthday and at Visits 1, 4, 5, 7, and 10 for subjects 12 years of age up to and including their 18th birthday, at the visit.

7.2.2 Vital Sign Measurements

Vital sign measurements (HR, SBP, and diastolic blood pressure [DBP]) will be obtained after the subject has rested for at least 5 minutes in either the supine or seated position. A single measurement of vital signs will be obtained as follows:

- Visit 1: before PFTs
- Visit 2: before pre-bronchodilator (albuterol) PFT for reversibility testing
- Visit 3: before pre-bronchodilator (ipratropium) PFT for reversibility testing
- Visits 4, 7, and 10/Final Visit: approximately 60 minutes pre-dose and 4 hours post-dose
- Visits 5, 6, 8, and 9: approximately 60 minutes pre-dose

For subjects who discontinue study drug or withdraw consent, a single measurement of vital signs will be obtained at the Treatment Discontinuation Visit or Study Withdrawal Visit, respectively.

7.2.3 12-Lead ECG

To standardize ECG collection, all sites will be provided with identical ECG equipment

[REDACTED] with customized study-specific software.

All study staff responsible for performing ECG collection will receive detailed training at the Investigator Meeting as well as site phone training sessions. Each site is required to demonstrate proficiency in the use of the equipment and the ability to perform technically acceptable ECGs prior to performing on study subjects. After each test has been performed, the ECG data will be transmitted electronically for centralized quality assurance review

[REDACTED] Feedback on the quality of the ECGs will be provided to the investigational site via a site qualification form.

A single ECG will be obtained as follows:

- At Visit 1
- At Visits 4, 5, 7, and 10/Final Visit within 60 minutes prior to dosing

For subjects who discontinue study drug or withdraw consent, a single ECG will be obtained at the Treatment Discontinuation or Study Withdrawal Visit.

The ECG parameters to be assessed include HR, PR interval, QRS axis, QRS interval, and QT/QTcF interval. The QT intervals and calculated QTcF intervals will be reviewed and checked for gross inaccuracies by the Investigator or designated ECG reviewer. Subjects who experience a change from their baseline ECG may need to discontinue study drug per criteria specified in Section 5.9.1.

7.2.4 Holter Monitoring: 24-Hour Continuous Electrocardiography

The following information applies only to those subjects participating in the 24-hour Holter monitoring sub-study.

Continuous Holter monitoring will be conducted over 24 hours at Visit 3 and at Visit 7. Holter monitor recordings are to be initiated in the morning at approximately the same time (± 2 hours) for these visits and 15 to 30 minutes before administration of the morning dose of ICS/LABA and, at Visit 7, study drug. Holter monitor procedures are summarized in Table 8-3.

Continuous Holter monitor recording will be collected for 24 hours. Holter monitor recordings must contain a minimum of 18 hours of acceptable quality recording in a 24-hour period to be deemed a successful Holter monitor assessment.

The designated service provider for Holter monitoring will be [REDACTED]. All Holter monitor recordings will be assessed for cardiac arrhythmias by an independent cardiologist appointed by [REDACTED].

7.2.4.1 Visit 3 Holter Monitoring Procedures

The Visit 3 (screening/baseline) Holter monitoring will be initiated following reversibility testing to ipratropium and 15 to 30 minutes before administration of the morning dose of ICS/LABA.

When the subject returns to the clinic the following day, the quality of the Holter monitor recordings will be assessed at the site. If the first Holter monitoring attempt is not successful (ie, <18 hours of acceptable quality recording), the Holter monitor will be reconnected for another 24 hours using a new Holter monitor hook-up kit. The subject will be instructed to continue his/her medications as per study protocol. The subject will return the following day for removal of the Holter monitor. This second attempt should be scheduled so that the Holter monitoring will be completed at least 24 hours before administration of the morning dose of study drug and ICS/LABA at Visit 4.

If the Holter monitoring recording remains inadequate on the second attempt, the subject will not be eligible to participate in the Holter monitoring sub-study, but DOES NOT need to be excluded from the full study. If clinically significant findings (as defined in Holter monitor exclusion criteria [Section 5.5]) are noted on any of the Holter monitor recordings, there will be no further attempts; the subject will be considered a screen failure and will not be eligible to enroll in the full study.

7.2.4.2 Visit 7 Holter Monitoring Procedures

At Visit 7, Holter monitoring will be initiated 15 to 30 minutes before administration of the morning dose of study drug and ICS/LABA in the clinic. Subjects will be instructed to return to the clinic the following day for removal of the Holter monitor.

When the subject returns to the clinic the following day, the quality of the Holter monitor recordings will be assessed at the site. If the first Holter monitoring attempt is not successful (ie, <18 hours of acceptable quality recording), the Holter monitor will be reconnected for another 24 hours using a new Holter monitor hook-up kit. The subject will be instructed to continue his/her medications as per study protocol. The subject will return the following day for removal of the Holter monitor. This second attempt should be scheduled so that the Holter monitoring will be placed on or before Visit 8.

If the Holter monitoring recording remains inadequate on the second attempt, there will be no further attempts.

7.2.4.3 Data for Analysis

Data for analysis will include the following:

- General trends including HR
- Hourly rhythm assessments
- Ventricular ectopy summary
- Ventricular run summary
- Supraventricular ectopy summary
- Supraventricular run summary
- Any other clinically relevant arrhythmias, including atrial fibrillation and pronounced bradycardia

Manual summary interpretation of the data will be sent as a report to the site and to the Sponsor.

7.2.5 Clinical Laboratory Tests

Subjects will be in a seated or supine position during blood collection.

Clinical safety laboratory tests will be analyzed by a central laboratory according to standardized, validated assays with the exception of urine pregnancy tests. The laboratory will supply detailed procedures for the preparation and collection of blood and urine samples along with all containers needed for their collection. Urine pregnancy tests will be performed at the clinical site using a commercially available test product.

Clinical laboratory tests performed during this study are shown in [Table 7-2](#).

Samples for clinical safety laboratory testing will be obtained at the following times:

- Blood
 - For hematology and clinical chemistry: Visit 1 (Screening) and prior to dosing at Visits 4, 5, 7, and 10/Final Visit, and the Treatment Discontinuation/Study Withdrawal Visit
 - For pregnancy (women of childbearing potential only): Visit 1 (Screening) and prior to dosing at Visit 10/Final Visit, and the Study Withdrawal Visit
- Urine
 - For urinalysis: Visits 1 (Screening), 4, and 10/Final Visit, and the Treatment Discontinuation/Study Withdrawal Visit.
 - For pregnancy (women of childbearing potential only): prior to dosing at Visits 2 through 9

Table 7-2 List of Clinical Safety Laboratory Tests

Hematology	
Hemoglobin	Mean corpuscular hemoglobin
Hematocrit	Mean corpuscular hemoglobin concentration
White blood cell count with differential	Mean corpuscular volume
Red blood cell count	Eosinophil count
Platelet count	
Clinical Blood Chemistry	
Liver Enzyme and Other Liver Function Tests	Other Clinical Blood Chemistry
Alanine aminotransferase	Albumin
Aspartate aminotransferase	Blood urea nitrogen
Alkaline phosphatase	Calcium
Bilirubin, total	Chloride
Gamma-glutamyl transferase	Cholesterol, total
	Bicarbonate
	Creatinine
	Glucose
	Magnesium
	Potassium
	Phosphate
	Protein, total
	Sodium
	Triglycerides
Urinalysis	
Macroscopic examination including specific gravity, pH, protein, glucose, ketones, blood, and urobilinogen.	
Other Tests	
<p><u>Pregnancy test for women of childbearing potential only</u>: Serum human chorionic gonadotropin (hCG) at Visits 1 and 10/Final Visit or Treatment Discontinuation/Study Withdrawal Visit; urine hCG at all other visits.</p> <p><u>Creatinine clearance</u> will be estimated by the central laboratory using the CKD-EPI formula (Levey et al 2009) for subjects >18 to 80 years of age or the Schwartz formula for subjects 12 to ≤18 years of age; where ≤18 years of age is defined as anyone less than 18 years of age up to and including their 18th birthday and >18 years of age is defined as 18 years +1 day and older (Schwartz et al 1987).</p>	

7.3 AEs

7.3.1 Performing AE Assessments

The Investigator is responsible for promptly documenting and reporting all AEs observed during the study in the subject's eCRF and on the AE reporting form. If the AE is unexpected, the Investigator should report the AE immediately to the Sponsor. In addition, certain AEs are classified as 'serious' (as described in Section 7.3.9) and must be reported no later than 24 hours after the Investigator recognizes/classifies the event as an SAE to the Sponsor or its designee.

In the case of SAEs, after discussing the details of the event, the Investigator and the Medical Monitor may discontinue the subject from study drug.

7.3.2 AE Definitions

The following definitions of terms are guided by the International Conference on Harmonisation (ICH) Technical Requirements for Registration of Pharmaceuticals for Human Use, the US Code of Federal Regulations (21 CFR 312.32) and European Union Directive 2001/83/EC and are included herein.

An AE is any untoward medical occurrence associated with the use of a drug in humans, whether or not considered drug related. An AE (also referred to as an adverse experience) can be any unfavorable and unintended sign (eg, an abnormal laboratory finding), symptom, or disease temporally associated with the use of a drug, without any judgment about causality. An AE can arise from any use of the drug (eg, off-label use, use in combination with another drug) and from any route of administration, formulation, or dose, including an overdose.

Adverse events include, but are not limited to the following:

- Any symptom or condition not previously reported by the subject (medical history)
- An exacerbation of a pre-existing symptom or condition
- A significant increase in frequency or intensity of a pre-existing episodic event or condition
- A drug interaction
- A condition first detected or diagnosed after study drug administration even though it may have been present prior to the start of the study

An AE does **not** include the following:

- Medical or surgical procedures (eg, surgery, endoscopy, tooth extraction, blood transfusion); the condition that leads to the procedure is an AE (eg, bleeding esophageal varices, dental caries)

- Overdose of either study drug or concurrent medication without any clinical signs or symptoms
- Abnormal laboratory values that are not clinically significant; if accompanied by signs/symptoms, the signs or symptoms are considered an AE

7.3.3 Pre-Randomization AEs

Any AE occurring from the time the subject signs informed consent until the subject is randomized will be summarized as medical history and not as an AE unless the event meets the definition of an SAE as defined in Section 7.3.9.

7.3.4 Severity

The Investigator must categorize the severity of each AE according to the following guidelines:

Mild: associated with no limitation of usual activities or only slight discomfort; generally not requiring alteration or cessation of study drug administration; and/or not needing therapeutic intervention

Moderate: associated with limitation of usual activities or significant discomfort; generally requiring alteration or cessation of study drug administration; and/or requiring therapeutic intervention

Severe: associated with inability of subject to carry out usual activities or very marked discomfort; considered to be life threatening; resulting in significant disability or incapacity; and requiring therapeutic intervention

7.3.5 Relationship to Study Drug

The Investigator will assess causal relationship between investigational product and each AE, and answer yes/no to the question, “Do you consider that there is a reasonable possibility that the event may have been caused by the investigational product?”

For SAEs, causal relationship will also be assessed for other medication and study procedures. Note that for SAEs that could be associated with any study procedure, the causal relationship is implied as ‘yes’.

7.3.6 Asthma Exacerbations and Associated Symptoms of Asthma

Asthma exacerbations may occur as a manifestation of asthma despite using standardized drug treatment or treatment(s) with combination therapies. As a result, the Sponsor has classified an asthma exacerbation as a protocol-specified expected event, and it is not to be reported as an AE unless considered an SAE. Moderate and severe asthma exacerbations must be captured on the asthma exacerbations eCRF; mild asthma exacerbations will be captured by the eDiary.

Since asthma exacerbations are expected events in this study, any individual case safety reports received related to an exacerbation of asthma will not be submitted on an expedited basis as a suspected unexpected serious adverse reaction unless further assessment is required by the Sponsor.

Associated symptoms of asthma (eg, wheeze, breathlessness, cough), the disease under study, will not be reported as AEs, unless considered an SAE.

7.3.7 AEs of Special Interest

Certain AEs have been identified as adverse events of special interest (AESIs) due to the class of drugs being studied. These AEs will be captured through spontaneous reports, and the reporting of these AESIs will be described in the statistical analysis plan (SAP). Some events are described below but this is not a comprehensive list of all AESIs.

7.3.7.1 LAMA Effects

Known effects of LAMAs include dry mouth, cardiovascular effects, ocular disorders, urinary retention, and gastrointestinal disorders.

7.3.7.2 Paradoxical Bronchospasm

Monitoring for paradoxical bronchospasm will occur at Visits 4, 5, 7, and 10/Final Visit at 15 and 30 minutes post-dose.

In this study, paradoxical bronchospasm is defined as a reduction in FEV₁ of >20% from baseline with associated symptoms of wheezing, shortness of breath, or cough that occur within 30 minutes post-dosing. Baseline is defined as the mean of the FEV₁ values obtained 60 and 30 minutes prior to study drug and ICS/LABA administration at that visit.

7.3.8 Clinical Laboratory AEs

Many laboratory abnormalities observed during the course of a study will be included under a reported AE describing a clinical syndrome (eg, elevated blood urea nitrogen and creatinine in the setting of an AE of renal failure, or decreased hemoglobin in a case of bleeding esophageal varices). Isolated laboratory abnormalities should be reported as AEs if they are considered to be clinically significant by the Investigator.

Criteria for a ‘clinically significant’ laboratory abnormality are the following:

- A laboratory abnormality that leads to a dose-limiting toxicity (eg, an abnormality that results in study drug dose suspension or treatment discontinuation)
- A laboratory abnormality that results in any therapeutic intervention (ie, concomitant medication or therapy)
- Other laboratory abnormality judged by the Investigator to be of any particular clinical concern (eg, significant fall in hemoglobin not requiring transfusion)

- For laboratory abnormalities that do not meet the above criteria, but are outside of normal range (eg, < or > normal reference range), the Investigator should indicate whether the value is clinically significant or not clinically significant for the subject.

7.3.9 SAEs

An AE is considered ‘serious’ if, in the view of the Investigator or Sponsor, it results in any of the following outcomes:

- Death
- A life-threatening AE
- In-patient hospitalization or prolongation of existing hospitalization
- A persistent or significant incapacity or substantial disruption of the ability to conduct normal life functions
- A congenital anomaly/birth defect

Important medical events that may not result in death, be life threatening, or require hospitalization may be considered serious when, based upon appropriate judgment, they jeopardize the subject or require medical or surgical intervention to prevent one of the outcomes listed in the definition. Examples of such medical events include allergic bronchospasm requiring intensive treatment in an emergency room or at home, blood dyscrasias or convulsions that do not result in subject hospitalization, or the development of drug dependency or drug abuse.

Hospitalization for a pre-existing condition (including elective procedures) that has not worsened does not constitute an SAE.

An AE or suspected adverse reaction is considered life threatening if, in the view of the Investigator or Sponsor, its occurrence places the subject at immediate risk of death. It does not include an adverse reaction or suspected adverse reaction that, had it occurred in a more severe form, might have caused death.

An AE or suspected adverse reaction is considered unexpected if it is not listed in the current IB or is not listed at the specificity or severity that has been observed.

7.3.9.1 Reporting SAEs

In agreeing to the provisions of this protocol, the Investigator accepts all legal responsibilities for AE identification, documentation, grading, assignment of causality, and prompt notification of SAEs to the Sponsor’s Pharmacovigilance Department or designee. All SAEs must be reported to the Sponsor Pharmacovigilance Department or designee no later than 24 hours after the Investigator recognizes/classifies the event as an SAE. All SAEs should be documented and reported using the eCRF. At a minimum, a description of the event and the

Investigator's judgment of causality must be provided at the time of the initial report using the appropriate form (eg, SAE report form). After the initial report, as necessary, the Investigator must provide any additional information on an SAE to the Sponsor's Pharmacovigilance Department or designee within 2 working days after receiving the information. Follow-up information will be a detailed written report that may include copies of hospital records, case reports, autopsy reports, and other pertinent documents.

For subjects who complete the entire study, all AEs/SAEs will be collected through 14 (+2) days after the last dose of study drug via a follow-up telephone call (see Section 8.11).

For subjects who discontinue randomized study drug but are planning to continue study participation (ie, planning to complete all remaining study visits and procedures), see Section 8.9.1, Treatment Discontinuation.

For subjects who withdraw from the study, see Section 8.9.2, [Study Withdrawal](#).

Post-treatment SAEs following the last dose of study drug must be reported to the Sponsor's Pharmacovigilance Department as described in Section 7.3.9.3.

The Investigator is responsible for continuing to report any new or relevant follow-up information that s/he learns about the SAE.

7.3.9.2 Supplemental Investigations of SAEs

The Investigator and supporting personnel responsible for subject care should discuss with the Sponsor Medical Monitor or designee any need for supplemental investigations of SAEs. If additional assessments are conducted, results must be reported to the Sponsor. If a subject dies during study participation and if a postmortem examination is performed, a copy of the autopsy report should be submitted to the Sponsor.

7.3.9.3 Notification of Post-Study SAEs

Investigators are not obligated to actively follow subjects after completion of the study. However, if the Investigator becomes aware of a post-study SAE occurring within the 14 days following the last dose, the SAE must be reported to the Sponsor, whether or not the event is attributable to study drug. All SAEs must be reported to the Sponsor no later than 24 hours after the Investigator recognizes/classifies the event as an SAE.

7.3.9.4 Institutional Review Board/Independent Ethics Committee Notification of SAEs

The Investigator is responsible for promptly notifying her/his Institutional Review Board (IRB)/Independent Ethics Committee (IEC) of all SAEs, including any follow-up information, occurring at their site and any SAE regulatory report, including any follow-up reports received from the Sponsor. Documentation of IRB/IEC submission must be retained for each safety report. The Investigator is also responsible for notifying the Sponsor if their IRB/IEC requires revisions to the ICF or other measures based on its review of an SAE Report.

7.3.9.5 Health Authority Safety Reports

The Sponsor or its representatives will submit a safety report to the appropriate regulatory agencies for any suspected adverse reaction that is both serious and unexpected within the timeframe specified by each regulatory agency.

The Sponsor or its representatives will send copies of each submitted safety report to Investigators actively participating in Pearl-sponsored clinical studies. Safety reports must also be submitted to the appropriate IRBs/IECs as soon as possible. Documentation of submission to the IRB/IEC must be retained for each safety report.

7.3.10 Post-Study Follow-Up of AEs and SAEs

Any AEs/SAEs that are unresolved at the subject's last AE assessment in the study are to be followed up by the Investigator for as long as medically indicated but without further recording in the eCRF. The Sponsor retains the right to request additional information for any subject with ongoing AE(s)/SAE(s) at the end of the study, if judged necessary.

7.3.11 Overdose

An overdose is defined as any dose greater than the highest dose investigated in this study that results in clinical signs and symptoms. In the event of a study drug overdose, the Investigator should use their best clinical judgment in treating the overdose, and the Sponsor's Medical Monitor should also be contacted. Investigators should refer to the relevant document(s) for detailed information regarding warnings, precautions, contraindications, AEs, and other significant data pertaining to the study drug(s) being administered. Such document(s) may include but are not limited to the IB for GP MDI and approved product labeling for open-label products.

7.3.12 Pregnancy

To ensure subject safety, each pregnancy from Visit 1 until study completion must be reported to the Sponsor within 24 hours of learning of its occurrence. The pregnancy should be followed in its entirety to ascertain outcome, including spontaneous or voluntary termination, details of the birth, and the presence or absence of any birth defects, congenital abnormalities, or maternal and/or newborn complications. Pregnancy should be recorded on a paper pregnancy report form and reported by the Investigator to the Sponsor's Pharmacovigilance Department or designee. Pregnancy follow-up should be recorded on the same pregnancy paper form and should include possible relationship to the study drug in response to the pregnancy outcome. Any SAE experienced during pregnancy must be reported on the SAE report form.

7.3.13 Paternal Exposure

If a male subject's partner becomes pregnant during the course of the study, it must be reported to the Sponsor within 24 hours of the Investigator learning of its occurrence.

7.3.14 Hy's Law

Cases where a subject shows an AST or ALT $\geq 3 \times \text{ULN}$ with TBL $\geq 2 \times \text{ULN}$ may need to be reported as SAEs. Please refer to [Appendix 12](#) for further instructions in cases of combined increase of aminotransferase and TBL.

7.3.15 Data Monitoring Committee

An independent, external Data Monitoring Committee (DMC) will be set up to review all SAEs (including deaths and all hospitalizations) and cardiovascular events. Members of the DMC will review summaries of these safety data generated externally and independently of the Sponsor in a semi-blinded or unblinded manner at predetermined intervals. If significant safety issues arise in between scheduled meetings, ad hoc meetings will be scheduled to review the data. Based on the safety implications of the data, the DMC may recommend modification or termination of the study.

7.4 Termination of Study

An Investigator may choose to discontinue study participation at any time, for any reason and should provide sufficient notice per the terms of the contract with the Sponsor.

The Sponsor reserves the right to terminate the study at any time for clinical or administrative reasons. Such a termination must be implemented by the Investigator, if instructed to do so by the Sponsor, in a timeframe that is compatible with the subjects' welfare.

8 STUDY ACTIVITIES

Please refer to Section 7 for a complete and detailed description of all study procedures and their respective timing. The overall schedule of events is provided in Table 8-1. A detailed schedule is provided for the timing of assessments of all post-randomization visits in Table 8-2. A detailed schedule of events for 24-hour Holter monitoring sub-study at Visits 3 and 7 is provided in Table 8-3.

8.1 General Study Considerations

- In order to minimize diurnal variance, sites should make every effort to assess subjects in clinic at the same time throughout the study. The first dose of study drug administered in the clinic should be planned to occur at approximately the same time the subject will typically administer study drug in the morning at home. However, sites should also make every effort to ensure that the morning study drug dosing occurs before 10 am.
- The subject should then be advised that subsequent morning study drug dosing should occur at approximately the same time every day and that evening study drug dosing should occur as close as possible to 12 hours from the time of morning study drug dosing.
- Sites should discuss the importance of study drug dosing at a consistent time linked to the time of study drug dosing at randomization. For example, if the study drug dose at randomization is administered at 8 am, all subsequent doses should be administered as close as possible to 8 am and 8 pm. In this case, all visits should be scheduled to support in-clinic dosing as close to 8 am (the timing of the initial dose at Visit 4) as possible.
- Subjects will be required to return to clinic at approximately the same time as Visit 1 for all treatment visits (± 1 hour) and dosing time should not exceed 10 am. Subjects will be required to remain at the clinic until completion of all protocol-defined assessments.
- The day before study visits, sites should contact subjects to confirm timing of the evening study drug dose and the expected timing of the in-clinic study drug dose. If the in-clinic dose will occur later than the subject typically takes their morning dose, the subject must be instructed to take their evening dose 12 hours prior to the expected in-clinic dosing time. Sites should instruct each subject as follows during this reminder phone call:
 - To take their last dose the evening before the scheduled visit
 - To bring their study medications and eDiary with them to the clinic
 - To withhold all inhaled medications (oral and intranasal) for at least 6 hours prior to PFTs
- Subjects who inadvertently took asthma medication(s) within 6 hours of the start of study procedures must have their clinic visit delayed (but not to exceed study drug dosing by 10 am) or rescheduled within the specified visit window.
- Subjects must not ingest xanthine and/or xanthine analogue (caffeine)-containing foods or beverages or caffeine-containing medications for at least 6 hours prior to each study visit and for the duration of each study visit. Examples of such products include coffee, tea, chocolate, and cola. Decaffeinated beverages are acceptable.

- Site personnel will instruct subjects not to take any asthma medications without site personnel permission during a clinic visit until all study procedures have been completed, and the subject is discharged. Site personnel should take every precaution to prevent subject use of asthma medications during the study visit. Subjects will be asked to abstain wherever possible from using rescue albuterol during study clinic visits. If a subject is experiencing severe symptoms and requires albuterol for relief of asthma symptoms at any time during a study visit, site personnel must note the time and justification of use in the subject's chart and all subsequent spirometry assessments should be stopped. However, safety assessments should be continued at the discretion of the Investigator.

Table 8-1 Schedule of Events

Procedures	Screening ^a			Treatment Period							Follow-Up TC	
	Visit 1 Day -28 to -9	Visit 2 ^b Day -21 to -2	Visit 3 Day -20 to -1	Visit 4 Rand Day 1	Visit 5 Week 4 Day 28±2	Visit 6 Week 8 Day 56±5	Visit 7 Week 12 Day 84±5	Visit 8 Week 16 Day 112±5	Visit 9 Week 20 Day 140±5	Visit 10/ Final Visit Week 24 ^o Day 168±5		14 (+2) days after last dose
Informed consent/assent	X											
Inclusion/exclusion criteria	X	X	X	X								
Verify continuing eligibility					X	X	X	X	X	X		
Randomization criteria				X								
Calculate PEFr stability limits				X								
Demographics and medical/surgical history ^d	X	X	X									
Prior/concomitant medications review ^e	X	X	X	X	X	X	X	X	X	X ^o	X	
Discontinue tiotropium (if applicable)	X											
Dispense/collect Sponsor-provided albuterol (as needed)	X	X	X	X	X	X	X	X	X	X ^o		
Dispense/collect Sponsor-provided ipratropium bromide HFA ^f	X			X								
Spirometry/PFTs ^g	X ^h	X ^h	X ^h	X	X	X	X	X	X	X		
F _{ENO}		X		X	X		X			X ^o		
Vital signs ⁱ	X	X	X	X	X	X	X	X	X	X ^o		
Blood collected for laboratory testing	X			X	X	X	X			X ^o		

Table 8-1 Schedule of Events

Procedures	Screening ^a			Treatment Period							Follow-Up TC	
	Visit 1 Day -28 to -9	Visit 2 ^b Day -21 to -2	Visit 3 Day -20 to -1	Visit 4 Rand Day 1	Visit 5 Week 4 Day 28±2	Visit 6 Week 8 Day 56±5	Visit 7 Week 12 Day 84±5	Visit 8 Week 16 Day 112±5	Visit 9 Week 20 Day 140±5	Visit 10/ Final Visit Week 24 ^o Day 168±5		14 (+2) days after last dose Day 182±2
Study Day ^c : Urine collected for laboratory testing	X			X							X ^o	
Pregnancy testing ^j	X	X	X	X	X	X	X	X	X		X ^o	
12-lead ECG	X			X							X ^o	
Holter monitor placement/removal ^k			X				X					
Physical examination ^l	X ¹										X ^o	
ACQ		X		X	X	X	X	X	X	X	X ^o	
AQLQ +12				X	X	X	X	X	X	X	X ^o	
Asthma exacerbations and AEs	X	X	X	X	X	X	X	X	X	X	X ^o	X
Inhalation device training ^p	X	X	X	X	X	X	X	X	X	X		
Inhalation device dose indicator training				X	X	X	X	X	X	X		
Study drug dispensing/collection				X	X	X	X	X	X	X	X ^o	
Administer subject's ICS/LABA (in-clinic) ^g		X	X	X	X	X	X	X	X	X	X	
Administer study drug in-clinic ^g				X	X	X	X	X	X	X	X	
eDiary: dispense/collect ^m	X										X ^o	
eDiary: training/review	X	X	X	X	X	X	X	X	X	X	X	

Table 8-1 Schedule of Events

Procedures	Screening ^a			Treatment Period						Follow-Up TC	
	Visit 1	Visit 2 ^b	Visit 3	Visit 4 Rand	Visit 5 Week 4	Visit 6 Week 8	Visit 7 Week 12	Visit 8 Week 16	Visit 9 Week 20		Visit 10/ Final Visit Week 24 ^c
Study Day ^c :	Day -28 to -9	Day -21 to -2	Day -20 to -1	Day 1	Day 28±2	Day 56±5	Day 84±5	Day 112±5	Day 140±5	Day 168±5	Day 182±2
Peak flow meter: training/dispense/collect ^m	X									X ^o	
Return to maintenance asthma medication		X ⁿ	X ⁿ	X ⁿ						X	

Abbreviations: ACQ= Asthma Control Questionnaire; AEs=adverse events; AQLQ +12=Asthma Quality of Life Questionnaire for 12 years and older; ECG=electrocardiogram; eDiary=electronic diary; FE_{NO}= fractional nitric oxide concentration in exhaled breath; HFA=hydrofluoroalkane; ICS/LABA=inhaled corticosteroid/long-acting β₂-agonist; PEFR=peak expiratory flow rate; PFTs=pulmonary function tests; Rand=randomization; TC=telephone call.

- ^a Screening Period of 11 to 28 days. Site should make every effort to maintain subjects within the scheduled visit windows. Subjects who fall outside the visit window will be placed in the appropriate window at the next scheduled visit.
- ^b Subjects will return for Visit 2 at least 7 days after Visit 1 to allow for eDiary compliance review and re-training as necessary.
- ^c Sites should call subjects 1 to 2 days before each scheduled visit to remind the subject of the visit and the required medication washouts and to bring all study-assigned medications and eDiary.
- ^d Collect medical history information at Visit 1 and update during the Screening Period if necessary.
- ^e Determine timing of last doses of short-acting bronchodilators, ICS/LABA, and study drug (Visits 5 through 10). Short-acting bronchodilators must be held for at least 6 hours prior to spirometry, and morning doses of ICS/LABA and study drug need to be withheld. With the exception of Visit 1, if these timelines have not been met, visits must be rescheduled and must occur within the specified windows. With the exception of reversibility testing, all other procedures at Visit 1 may take place if subjects did not withhold these medications.
- ^f Subjects taking tiotropium will discontinue this medication and be provided ipratropium to take 2 puffs QID until 6 hours prior to spirometry on the morning of Visit 4. All subjects will continue taking their regular ICS/LABA and will use Sponsor-provided albuterol as needed for rescue.
- ^g All pre-dose (trough) spirometry and all in-clinic dosing must occur between 7 am and 10 am and within ±1 hour of the Visit 1 time and approximately 12 hours after the evening dose of BID study treatments (see Section 8.1). Subjects will be required to return to the clinic at approximately the same time as Visit 1 for all treatment visits (±1 hour).
- ^h Subjects will be tested for reversibility at 30 minutes following 4 puffs of albuterol (Visit 1 and, if needed, Visit 2) and ipratropium (Visit 3). If subjects are not reversible at 30 minutes, the post-dose PFT can be repeated at 60 minutes post-dose for qualification for albuterol (Section 7.1.1.3). Spirometry is not

required at Visit 2 unless the subject does not demonstrate reversibility to albuterol at Visit 1. If pre-dose spirometry is performed at Visit 2 due to the subject not demonstrating reversibility to albuterol at Visit 1, the pre-dose FEV₁ should be >40% and <85 % of predicted normal for subjects 18 to 80 years of age or >40% and <90% for subjects 12 to <18 years of age. Repeat spirometry at 60 minutes post-dose is not necessary for reversibility testing to ipratropium.

- i Vital signs include HR and blood pressure only.
- j Serum pregnancy test at Visits 1 and 10/Final Visit or Study Withdrawal Visit; urine pregnancy test at all other visits.
- k Holter monitor will be placed on subjects participating in the Holter monitoring sub-study at Visits 3 and 7 and removed the following day. If Holter data are unacceptable, the Holter monitor will be reconnected for another 24 hours. The repeat Holter monitor following Visit 3 must be removed at least 24 hours prior to scheduled Visit 4 and the repeat Holter monitor following Visit 7 must be placed on or before Visit 8. Refer to Section 7.2.4 and Table 8-3 for additional details.
- l Includes evaluation of weight at Visit 1 and Visit 10/Final Visit for all subjects and height at Visit 1 for subjects who have had their 18th birthday and at Visits 1, 4, 5, 7, and 10 for subjects 12 years of age up to and including their 18th birthday, at the visit.
- m Issue and train subjects on eDiary and peak flow meter use only after subject has been found eligible to proceed to Visit 2. Subjects will use the eDiary to maintain a record of their rescue medication use, morning and evening asthma symptoms, ICS/LABA administration (Screening Period only; this will be QD for ICS/LABAs that are only administered QD and BID otherwise), and study drug dosing (Treatment Period only) (refer to Section 7.1.2 for specifics). Daily morning and evening pre-dose PEFs will automatically be recorded in the eDiary.
- n Screening failure subjects only
- o These are minimum procedures that should be completed for Treatment Discontinuation and/or Study Withdrawal Visits (refer to Section 8.9 for additional details).
- p If MDI training is needed, Ventolin MDI or Atrovent MDI can be used; no Placebo MDI will be provided for training purposes.

Table 8-2 Sequence and Timing for Selected Assessments at Treatment Visits 4 through 10

Assessment	Visit(s)	Pre-dose			Post-dose		
		Not Timed	At -60 min	At -30 min	15 min / 30 min / 1 hr / 2 hr	4 hr	
Determine if asthma drugs were withheld ^a	All	X ^a					
Perform ACQ and AQLQ +12 ^b	All	X ^b					
Record vital signs (HR, DBP, and SBP) ^c							
Pre-dose	All	X ^{b,c}					
Post-dose	4, 7, and 10/FV						X ^c
Record 12-lead ECG ^b	4, 5, 7, and 10/FV	X ^b					
Collect blood and urine for clinical laboratory testing ^d							
Hematology and chemistry ^d	4, 5, 7, and 10/FV			X ^d			
Urinalysis ^d	4 and 10/FV			X ^d			
Pregnancy test ^d	4-9 and 10/FV			X ^d			
Measure F _{ENO}	4, 5, 7, and 10/FV	X ^b					
Review eDiary including PEFR	All	X ^{a,b}					
Perform spirometry							
Pre-dose ^e	All		X ^e		X ^e		
Post-dose ^f	4, 7, and 10/FV		X ^f		X ^f	X ^f	X ^f
Collect study drug	5 through 10/FV	X ^b					
Dispense study drug ^g	All						X ^{b,g}
Schedule next visit ^h	4 through 9						X ^{b,h}

Abbreviations: ACQ= Asthma Control Questionnaire; AQLQ +12=Asthma Quality of Life Questionnaire for 12 years and older; DBP=diastolic blood pressure; ECG=electrocardiogram; eDiary=electronic diary; F_{ENO}= fractional nitric oxide concentration in exhaled breath; HR=heart rate; PEFR=peak expiratory flow rate; SBP=systolic blood pressure. (Footnotes continued on next page.)

Note: Time point for study drug and ICS/LABA dosing is regarded as “0 minutes” and pre- and post-dose are relative to study drug and ICS/LABA dosing. When data collection time points are concurrent, variables should be collected in the following order: ACQ, AQLQ +12, vital signs, ECG, clinical laboratory samples, FE_{NO}, eDiary review, and spirometry.

- a At the start of the Treatment Visit, subjects must have withheld morning doses of study drug and ICS/LABA (and ipratropium, as applicable, for Visit 4) and rescue albuterol for at least 6 hours prior to start of test day procedures.
- b This assessment should be performed pre-dose, at an appropriate time to allow for collection of timed pre-dose spirometry.
- c Vital signs (HR, DBP, and SBP only) should be started approximately 5 to 10 minutes ahead of the specified time point to ensure spirometry will be conducted as close as possible to the specified time points.
- d Samples for clinical laboratory tests will be collected within 60 minutes prior to dosing. Pregnancy tests will be performed on urine (on site) before study drug and ICS/LABA dosing at Visits 4 through 9, and on serum at Visit 10/Final Visit.
- e Pre-dose spirometry must be performed between 7 am and 10 am, within ± 1 hour of the time of the Visit 1 spirometry, ± 15 minutes of the specified time before study drug and ICS/LABA administration and, for subjects randomized to BID study drug treatment, approximately 12 hours after the evening study drug dose.
- f Post-dose spirometry should be conducted ± 5 minutes of the specified time for the first 60 minutes after study drug and ICS/LABA administration, and ± 15 minutes of the specified time point for assessments obtained thereafter.
- g Dispense study drug to subjects for at-home use. At Visit 10, study drug will be dispensed for the final in-clinic dose only.
- h Schedule next visit following completion of all post-dose assessments.

Table 8-3 Schedule of Events for 24-hour Holter Monitoring Sub-Study at Visits 3 and 7

Procedures	Screening Period			Treatment Period			
	Visit 3	Visit 3 +1 Day	Visit 3 +2 Days	Visit 7	Visit 7 +1 Day	On or Before Visit 8	On or Before Visit 8 +1 Day
Begin 24-hour Holter monitoring (1 st attempt)	X ^a			X ^b			
Remove Holter monitor (1 st attempt)		X ^c			X ^c		
Begin 24-hour Holter monitoring (2 nd attempt)		X ^d				X ^e	
Remove Holter monitor (2 nd attempt)			X ^f				X ^f

Note: Subjects who discontinue treatment before Week 12 will NOT be eligible for Visit 7 Holter assessment.

- a Attach Holter monitoring device and initiate 24-hour recording following the post-ipratropium spirometry assessment **and** 15 to 30 minutes before administration of the morning dose of ICS/LABA.
- b Attach Holter monitoring device and initiate 24-hour recording following the pre-dose spirometry assessments **and** 15 to 30 minutes before administration of the morning dose of study drug and ICS/LABA.
- c Site personnel determine the acceptability of the Holter monitor recording.
- d If the Visit 3 Holter monitor recordings are not successful (acceptable recordings for ≥ 18 hours) on the first attempt, a second attempt will be made using a new Holter monitor hook-up kit. The repeat Holter monitor must be removed at least 24 hours prior to scheduled Visit 4. Subjects can continue in the Holter monitoring sub-study provided an acceptable recording for ≥ 18 hours has been obtained and no clinically significant findings (as defined in Section 5.5) are reported by [REDACTED] following review of the Holter monitor recordings. Refer to Section 7.2.4 for additional details.
- e If the Visit 7 Holter monitor recordings are not successful (acceptable recordings for ≥ 18 hours) on the first attempt, a second attempt will be made using a new Holter monitor hook-up kit. The repeat Holter monitor must be placed on or before Visit 8. Refer to Section 7.2.4 for additional details.
- f No further attempts will be allowed if the second attempt is unsuccessful.

8.2 Visit 1 (Day –28 to –9)

- Obtain informed consent (and assent if applicable)
- Register subject in IWRS to obtain subject screening number
- Obtain demographic data, including age, race, and smoking and medical/surgical histories
- Obtain prior and concurrent medication history, including all asthma medications
- If the subject withheld morning dose(s) of regular asthma medications and has not administered albuterol within at least 6 hours prior to testing, conduct spirometry assessments (Section 7.1.1) between 7 am and 10 am including reversibility to albuterol (see Section 7.1.1.3). If the subject meets reversibility to albuterol criteria (defined in Section 7.1.1.3), reversibility testing will not be repeated at Visit 2. If the subject has not withheld their dose(s) of regular asthma medications (Section 8.1) or albuterol, Visit 1 should be rescheduled no sooner than the following day.
- Obtain vital signs (HR, SBP, and DBP) after the subject has been seated or supine for at least 5 minutes
- Conduct a complete physical examination (ie, height, weight, general appearance, skin, head, eyes, ears, nose, throat, neck [including thyroid], lymph nodes, chest, heart, abdomen, extremities, and nervous system)
- Confirm subject's ability to use inhalation device correctly (provide coaching as needed)
- Obtain a 12-lead ECG
- Verify that the subject meets inclusion/exclusion criteria.
- Once the subject has completed the above assessments and after determining that the subject is eligible to continue to Visit 2, complete the following:
 - Obtain blood and urine for hematology, chemistry, and urinalysis tests
 - Obtain blood for a serum pregnancy (hCG) test for all female subjects unless it is documented in the medical history that the subject has been irreversibly surgically sterilized (hysterectomy, bilateral oophorectomy, or bilateral tubal ligation), is at least 2 years post-menopausal, or has not started menses
- Instruct subjects taking tiotropium to discontinue this medication and begin ipratropium 2 puffs QID during the Screening Period. The first dose should be taken in the clinic after all spirometry and reversibility testing has been completed. Ipratropium should not be taken the morning of study clinic Visit 2.
- Dispense albuterol for use as rescue medication
- Review required minimum washout criteria for other asthma medications (Table 5-2)
- Dispense and train subjects on eDiary and PEFr meter use

- Schedule Visit 2: the timing of Visit 2 should coincide with the timing of Visit 1 in order to obtain pre-dose spirometry data between 7 am and 10 am **and** within ± 1 hour of the time of the Visit 1 spirometry assessment
- Instruct the subject to do the following:
 - continue treatment with their ICS/LABA (and ipratropium, if applicable) along with Sponsor-provided albuterol for rescue
 - withhold ICS/LABA and albuterol (and ipratropium, if applicable) on the morning of Visit 2
 - albuterol (and ipratropium, if applicable) should be withheld for a minimum of 6 hours before Visit 2bring their eDiary, ICS/LABA (and ipratropium, if applicable), and Sponsor-provided rescue albuterol to the next scheduled clinic visit
- Record asthma exacerbations and AEs (if any). AEs must be reported in the eCRF as part of medical history (unless they meet seriousness criteria, which will be recorded as an SAE) during the Screening Period from the time of signing informed consent.

Note: It is recommended that sites call subjects the day BEFORE their scheduled Visit 2 to remind them of all expectations.

8.3 Visit 2 (Day –21 to Day –2)

- Determine if subjects have withheld their morning doses ICS/LABA (and ipratropium, if applicable) and meet required washout timing of all prior asthma medications (Table 5-2). The date and time of last dose of rescue albuterol should be documented. If it has been < 6 hours since the time of the last dose of short-acting bronchodilators, or if the morning dose of ICS/LABA dose was not held or the washout periods were not met, the clinic visit must be rescheduled.
- Re-assess eligibility for the study by reviewing inclusion and exclusion criteria
- Complete ACQ-5
- If not previously reviewed, review clinical laboratory testing results from Visit 1 and record any clinically significant findings
- Review/update concomitant medication history
- Perform urine pregnancy test for all females of child-bearing potential
- Obtain vital signs (HR, SBP, and DBP only)
- Perform reversibility testing to albuterol (Section 7.1.1.3) if not completed at Visit 1 or if albuterol reversibility criteria were not met at Visit 1
- Confirm subject's ability to use inhalation device correctly (provide coaching as needed)
- Review the eDiary; re-train if subject has not met the eDiary compliance requirement

- Record asthma exacerbations and AEs (if any). AEs must be reported in the eCRF as part of medical history (unless they meet seriousness criteria, which will be recorded as an SAE) during the Screening Period from the time of signing informed consent.
- Obtain F_{ENO} (see Section 7.1.5)
- Dose with subject's ICS/LABA
- Dispense additional albuterol for use as rescue medication, if needed
- Schedule Visit 3. The timing of Visit 3 should coincide with the timing of Visit 1 in order to obtain spirometry data between 7 am and 10 am **and** within ± 1 hour of the time of the Visit 1 spirometry assessment.
- Instruct the subject to continue to do the following:
 - continue treatment with their ICS/LABA (and ipratropium, if applicable) along with Sponsor-provided albuterol for rescue
 - withhold ICS/LABA and albuterol (and ipratropium, if applicable) on the morning of Visit 3
 - albuterol (and ipratropium, if applicable) should be withheld for a minimum of 6 hours before Visit 3
 - bring their eDiary, ICS/LABA (and ipratropium, if applicable), and Sponsor-provided rescue albuterol to the next scheduled clinic visit

Note: It is recommended that sites call subjects the day BEFORE their scheduled Visit 3 to remind them of all expectations

Note: If the subject screen fails, then return the subject to their maintenance asthma medications.

8.4 Visit 3 (Day –20 to Day –1)

- Determine if subjects have withheld their morning doses ICS/LABA (and ipratropium, as appropriate). The date and time of last dose of rescue albuterol should be documented. If there has been <6 hours since the time of the last dose of rescue albuterol, or if the morning dose of ICS/LABA dose was not held (and ipratropium, if applicable), the clinic visit must be rescheduled.
- Re-assess eligibility for the study by reviewing inclusion and exclusion criteria
- Review/update concomitant medication history
- Record asthma exacerbations and AEs (if any). AEs must be reported in the eCRF as part of medical history (unless they meet seriousness criteria, which will be recorded as an SAE) during the Screening Period from the time of signing informed consent.
- Confirm subject's ability to use inhalation device correctly (provide coaching as needed)
- Review eDiary with subject; re-train if subject has not met eDiary compliance requirement

- Perform urine pregnancy test for all females of child-bearing potential
- Obtain vital signs (HR, SBP, and DBP)
- Perform spirometry before and after ipratropium administration to determine reversibility (see Section 7.1.1.3 for instructions)
- If a subject is participating in the 24-hour Holter monitoring sub-study, attach Holter monitor and initiate 24-hour Holter monitor recording following the post-ipratropium spirometry assessment and 15 to 30 minutes before ICS/LABA dosing (see Section 7.2.4 and Table 8-3 for further instructions)
- Dose with subject's ICS/LABA
- Dispense additional albuterol for rescue use, if needed
- Schedule a visit on the following day to remove Holter (see Section 7.2.4)
- Schedule Visit 4. The timing of Visit 4 should coincide with the timing of Visit 1 in order to obtain spirometry data between 7 am and 10 am **and** within ± 1 hour of the time of the Visit 1 spirometry assessment.
Note: For the remainder of the study, the timing of pre-dose clinic spirometry at all subsequent visits must occur between 7 am and 10 am **and** be within ± 1 hour of the time of the spirometry conducted at Visit 1
- Instruct the subject to continue to do the following:
 - continue treatment with their ICS/LABA (and ipratropium, if applicable) along with Sponsor-provided albuterol for rescue
 - return the following day for removal of the Holter monitor
 - withhold ICS/LABA and albuterol (and ipratropium, if applicable) on the morning of Visit 4
 - albuterol (and ipratropium, if applicable) should be withheld for a minimum of 6 hours before Visit 4
 - bring their eDiary, ICS/LABA (and ipratropium, if applicable), and Sponsor-provided rescue albuterol to Visit 4

Note: It is recommended that sites call subjects the day BEFORE their scheduled Visit 4 to remind them of all expectations

Note: If the subject screen fails, then return the subject to their maintenance asthma medications.

8.5 Visit 4 (Randomization, Day 1)

There are timed and untimed assessments at Visit 4 (see Table 8-1 and Table 8-2). All pre-dose assessments are to be completed within 30 to 60 minutes before dosing.

- Determine if subject has withheld their morning dose of ICS/LABA (and ipratropium, as appropriate). The date and time of last dose of rescue albuterol should be documented. If it has been <6 hours since the time of the last dose of rescue albuterol, or if the morning dose of ICS/LABA dose (and ipratropium, if applicable) was not held, the clinic visit must be rescheduled.
- Review subject eDiary including peak flow values. Screen fail subject if subject has not met eDiary compliance requirement (See Section 5.2).
- Review/update concomitant medication history
- Re-assess eligibility for the study by reviewing inclusion and exclusion criteria
- Obtain height for subjects 12 years of age up to and including their 18th birthday, at the visit
- Complete all pre-dose assessments (refer to Table 8-2) in recommended order
 - Conduct -60 and -30 minute pre-dose spirometry. Pre-dose spirometry must be completed between 7 am and 10 am **and** within ± 1 hour of the spirometry conducted at Visit 1.
- Provide inhalation device and dose indicator training (for GP MDI and Placebo MDI use, see Appendix 5; for Spiriva Respimat use, see Appendix 6; for dose-indicator instructions for GP MDI and Placebo MDI, see Appendix 4)
- Record asthma exacerbations and AEs (if any).
- Discontinue and collect ipratropium supplies from screening
- Determine eDiary-calculated PEFr stability limit (Section 7.1.2.3)
- Confirm eligibility for randomization (Section 5.3)
- Subjects who are not eligible for randomization will be considered screen failures. The reason for the subject's failure to qualify for randomization will be collected. Subjects who have not qualified for randomization will be instructed to restart their previous asthma maintenance medications before being discharged from the study.
- Obtain subject randomization number and treatment assignment information from IWRS
- Dispense study drug. To allow for proper preparation of study drug, it is recommended that the seal around the study day treatment box is opened 15 to 30 minutes prior to dosing and the instructions for administration of study drug followed:
 - See Section 6.5 for detailed instructions for preparation of study drugs for administration. These instructions are to be adhered to and are relevant to all study treatment visits.
 - Record/document the dose indicator reading. The dose indicator count recorded by the site staff will be the dose indicator count observed after priming but prior to subject dosing.
- Once study drug is primed and ready for use, provide assigned study drug to subject.

- Administer study drug and ICS/LABA at the clinic
- Complete post-dose spirometry and vital signs (refer to [Table 8-2](#))
- Upon completion of post-dose spirometry and vital signs, dispense additional albuterol for rescue use, if needed
- Schedule Visit 5: the timing of Visit 5 should coincide with the timing of Visit 1 in order to obtain spirometry data between 7 am and 10 am **and** within ± 1 hour of the time of the Visit 1 spirometry assessment **and**, if randomized to a BID study drug, be approximately 12 hours after the evening dose of study drug.
- Instruct subject to do the following:
 - continue treatment with ICS/LABA and study drug at home, along with Sponsor-provided albuterol for rescue
 - withhold their ICS/LABA, study drug, and albuterol on the morning of Visit 5
 - albuterol should be withheld for a minimum of 6 hours before Visit 5
 - bring their eDiary, ICS/LABA, and Sponsor-provided rescue albuterol to Visit 5**Note:** It is recommended that sites call subjects the day BEFORE their scheduled Visit 5 to remind them of all expectations.

Note: It is recommended that sites call subjects the day BEFORE their next scheduled visit to remind them of all expectations.

8.6 Visits 5, 6, 8, and 9 (Weeks 4, 8, 16, and 20)

The following procedures will be completed:

- Determine if subjects have withheld their morning doses of ICS/LABA and study drug. The date and time of last dose of rescue albuterol should be documented. If it has been <6 hours since the time of the last dose of albuterol, or if the morning doses of ICS/LABA and/or study drug were not held, the clinic visit must be rescheduled.
- Review/update concomitant medication history
- Re-assess eligibility for the study by reviewing inclusion and exclusion criteria
- Obtain height for subjects 12 years of age up to and including their 18th birthday, at the visit (Visit 5 only)
- Complete all pre-dose assessments (refer to [Table 8-2](#)) in recommended order
- Conduct -60 and -30 minute pre-dose spirometry. Pre-dose spirometry must be completed between 7 am and 10 am **and** within ± 1 hour of the spirometry conducted at Visit 1 **and**, if randomized to a BID study drug, be approximately 12 hours after the evening dose of study drug.
- Record asthma exacerbations and AEs (if any)
- Provide inhalation device and dose indicator training (see [Section 8.5](#))

- Perform urine pregnancy test for all females of child-bearing potential
- Dispense study drug. To allow for proper preparation of study drug, it is recommended that the seal around the study day treatment box is opened 15 to 30 minutes prior to dosing and the instructions for administration of study drug followed:
 - See Section 6.5 for detailed instructions for preparation of study drugs for administration. These instructions are to be adhered to and are relevant to all study treatment visits.
 - Record/document the dose indicator reading. The dose indicator count recorded by the site staff will be the dose indicator count observed after priming but prior to subject dosing.
- Administer study drug and ICS/LABA at the clinic
- Dispense additional albuterol for rescue use, if needed
- Schedule the next visit: the timing of each visit should coincide with the timing of Visit 1 in order to obtain spirometry data between 7 am and 10 am **and** within ± 1 hour of the time of the Visit 1 spirometry assessment **and**, if randomized to a BID study drug, be approximately 12 hours after the evening dose of study drug.
- Instruct subject to do the following:
 - continue treatment with ICS/LABA and study drug at home, along with Sponsor-provided albuterol for rescue
 - withhold their ICS/LABA, study drug, and albuterol on the morning of the next visit
 - albuterol should be withheld for a minimum of 6 hours before the next visit
 - bring their eDiary, ICS/LABA, and Sponsor-provided rescue albuterol to the next visit

Note: It is recommended that sites call subjects the day BEFORE their next scheduled visit to remind them of all expectations.

8.7 Visit 7 (Week 12)

The following procedures will be completed:

- Determine if subjects have withheld their morning doses of ICS/LABA and study drug. The date and time of last dose of rescue albuterol should be documented. If it has been <6 hours since the time of the last dose of albuterol, or if the morning doses of ICS/LABA and/or study drug were not held, the clinic visit must be rescheduled.
- Review/update concomitant medication history
- Re-assess eligibility for the study by reviewing inclusion and exclusion criteria
- Obtain height for subjects 12 years of age up to and including their 18th birthday, at the visit

- Complete all pre-dose assessments (refer to [Table 8-2](#)) in recommended order
- Conduct -60 and -30 minute pre-dose spirometry. Pre-dose spirometry must be completed between 7 am and 10 am **and** within ± 1 hour of the spirometry conducted at Visit 1 **and**, if randomized to a BID study drug, be approximately 12 hours after the evening dose of study drug.
- Record asthma exacerbations and AEs (if any)
- Provide inhalation device and dose indicator training (see [Section 8.5](#))
- If a subject is participating in the 24-hour Holter monitoring sub-study, attach Holter monitor and initiate 24-hour Holter monitoring. The Holter monitor will be removed the following day (see [Section 7.2.4](#), [Table 8-1](#), and [Table 8-3](#) for further instructions)
- Dispense study drug. To allow for proper preparation of study drug, it is recommended that the seal around the study day treatment box is opened 15 to 30 minutes prior to dosing and the instructions for administration of study drug followed:
 - See [Section 6.5](#) for detailed instructions for preparation of study drugs for administration. These instructions are to be adhered to and are relevant to all study treatment visits.
 - Record/document the dose indicator reading. The dose indicator count recorded by the site staff will be the dose indicator count observed after priming but prior to subject dosing.
- Administer study drug and ICS/LABA at the clinic; at Visit 7 (15 to 30 minutes after Holter monitoring is initiated, if applicable)
- Complete post-dose spirometry and vital signs (refer to [Table 8-2](#))
- Upon completion of post-dose spirometry and vital signs, dispense additional albuterol for rescue use, if needed
- Schedule the next visit: the timing of each visit should coincide with the timing of Visit 1 in order to obtain spirometry data between 7 am and 10 am **and** within ± 1 hour of the time of the Visit 1 spirometry assessment **and**, if randomized to a BID study drug, be approximately 12 hours after the evening dose of study drug.
- Instruct subject to do the following:
 - continue treatment with ICS/LABA and study drug at home, along with Sponsor-provided albuterol for rescue
 - withhold their ICS/LABA, study drug, and albuterol on the morning of the next visit
 - albuterol should be withheld for a minimum of 6 hours before the next visit
 - bring their eDiary, ICS/LABA, and Sponsor-provided rescue albuterol to the next visit

Note: It is recommended that sites call subjects the day BEFORE their next scheduled visit to remind them of all expectations.

8.8 Final Visit (Visit 10, Week 24)

- Determine if subjects have withheld their morning dose of ICS/LABA. The date and time of last dose of rescue albuterol should be documented. If it has been <6 hours since the time of the last dose of short-acting bronchodilators, or if the morning dose of ICS/LABA was not held, the clinic visit must be rescheduled.
- Re-assess eligibility for the study by reviewing inclusion and exclusion criteria
- Review/update concomitant medication history
- Obtain height for subjects 12 years of age up to and including their 18th birthday, at the visit
- Complete all pre-dose assessments (refer to [Table 8-2](#)) in recommended order
- Conduct -60 and -30 minute pre-dose spirometry. Pre-dose spirometry must be completed between 7 am and 10 am **and** within ± 1 hour of the spirometry conducted at Visit 1 **and**, if randomized to a BID study drug, be approximately 12 hours after the evening dose of study drug.
- Record asthma exacerbations and AEs (if any)
- Conduct a complete physical examination
- Obtain F_{ENO} (see Section [7.1.5](#))
- Dispense study drug for this final visit. To allow for proper preparation of study drug, it is recommended that the seal around the study day treatment box is opened 15 to 30 minutes prior to dosing and the instructions for administration of study drug followed:
 - See Section [6.5](#) for detailed instructions for preparation of study drugs for administration. These instructions are to be adhered to and are relevant to all study treatment visits.
 - Record/document the dose indicator reading. The dose indicator count recorded by the site staff will be the dose indicator count observed after priming but prior to subject dosing.
- Administer study drug and ICS/LABA at the clinic
- Complete post-dose spirometry and vital signs (refer to [Table 8-2](#))
- Upon completion of post-dose procedures, complete the following:
 - Collect dispensed study drug and Sponsor-provided albuterol
 - Collect dispensed peak flow meter and eDiary
 - Instruct subject to resume treatment with maintenance asthma medications per Investigator's judgment
 - Schedule the follow-up telephone call if needed (see Section [8.11](#))

8.9 Procedures for Treatment Discontinuation and Study Withdrawal Visits

Subjects who discontinue study drug (treatment) before the end of the study will be encouraged to remain in the study to complete all remaining study visits and procedures during the randomized Treatment Period. Procedures for subjects who agree to be followed after treatment discontinuation are described in Section 8.9.1 and procedures for subjects who withdraw from study participation are described in Section 8.9.2.

8.9.1 Treatment Discontinuation

Subjects who agree to continue to be followed beyond discontinuation of only study treatment will sign an ICF/assent addendum and complete a Treatment Discontinuation Visit (see Section 8.9.3) before transitioning back to regularly scheduled study visits. No 14-day follow-up phone call is needed if the subject completes a study visit \geq 14 days after the Treatment discontinuation visit. After the Treatment Discontinuation Visit, subjects will return to appropriate maintenance asthma medications at the Investigator's discretion, and the prohibited medications in Section 5.7 will no longer apply.

For subjects who discontinue randomized study drug (ie, Treatment Discontinuation) but are planning to continue study participation (ie, planning to complete all remaining study visits and procedures), all AEs/SAEs will be collected through the last study visit or early termination visit.

8.9.2 Study Withdrawal

If a subject discontinues study treatment and chooses not to continue with study assessments, the subject should complete at least the minimum procedures for Visit 10/Final Visit at the Study Withdrawal Visit (see Section 8.9.3). After that visit, subjects will return to appropriate maintenance asthma medications at the Investigator's discretion.

All AEs/SAEs will be collected through 14 (+2) days after the last dose of study drug. This can occur via a follow-up telephone call (Section 8.11) or a study visit, whichever follow-up type provides 14 (+2) days of AE/SAE follow-up.

8.9.3 Study Visit Procedures

Unless otherwise indicated, the following minimum procedures will be completed for either a Treatment Discontinuation Visit or a Study Withdrawal Visit:

- Complete ACQ and AQLQ +12
- Record asthma exacerbations and AEs (if any)
- Review/update concomitant medication history
- Conduct a physical examination and assess vital signs (HR, SBP, and DBP only)

- Perform ECG and collect blood and urine samples for clinical laboratory testing (hematology, chemistries, urinalysis, pregnancy test; see Section 7.2.5)
- Obtain FE_{NO} (see Section 7.1.5)
- Collect study drug and Sponsor-provided albuterol
- Collect subject eDiary and peak flow meter (for Study Withdrawal Visit only)
- Return subject to pre-study or appropriate maintenance asthma medications
- Inform subject about reporting all SAEs for 14 (+2) days following the last dose of study drug
- Capture the reason for subject discontinuation

8.10 Repeat Assessments and Treatment Discontinuation and/or Study Withdrawal Visits

Repeat assessments, if needed, will be captured as Unscheduled Visits in the eCRF.

Treatment Discontinuation Visits and Study Withdrawal Visits will also be captured as Unscheduled Visits in the eCRF.

Procedures for the Treatment Discontinuation Visit and Study Withdrawal Visit are shown in Section 8.9.

8.11 Follow-Up Telephone Call

For subjects that complete 24 weeks of study drug, use of concomitant medications and AEs/SAEs (if any) will be collected through 14 (+2) days after the last dose of study drug. Previously ongoing asthma exacerbations will also be reviewed. This can occur via a follow-up telephone call or a study visit, whichever follow-up type provides 14 (+2) days of concomitant medication and AE/SAE follow-up.

8.12 Completion of the Study

The Investigator will document study completion or the reason for early study drug discontinuation or study withdrawal by a subject in the eCRF.

The following categories should be used to describe these events in the eCRF:

- Subject discretion (document reason)
- Investigator considers it to be in the best interest of the subject
- AEs/SAEs
- Administrative reasons (eg, early termination of the study)
- Subject lost to follow-up

- Lack of efficacy
- Major protocol deviation
- Death
- Completion of the study
- Protocol-specified criteria (Section [5.9](#))

9 STATISTICAL METHODS

9.1 Introduction

This is a double-blind, parallel group study evaluating the efficacy and safety of 3 doses of GP MDI compared to Placebo MDI and open-label Spiriva Respimat over a 24-week Treatment Period in approximately 1125 subjects with persistent asthma who are symptomatic despite treatment with an ICS/LABA or ICS/LABA + tiotropium. During the Screening and Treatment Periods, subjects will remain on their ICS/LABA regimen. At randomization, subjects will be randomized in a 2:2:2:2:1 ratio to 1 of the following 5 treatment groups:

- GP MDI 28.8 µg BID (n=250)
- GP MDI 14.4 µg BID (n=250)
- GP MDI 7.2 µg BID (n=250)
- Placebo MDI BID (n=250)
- Spiriva Respimat 2.5 µg QD (n=125)

The primary objective of this study is to assess the effect of 3 doses of GP MDI compared to Placebo MDI and Spiriva Respimat on lung function over 24 weeks.

9.2 Protocol Variables

The study endpoints are found in Section 3.

9.3 Analysis Sets and Estimands

9.3.1 Analysis Sets

The following analysis sets are defined in this study:

- The Intent-to Treat (ITT) analysis set is defined as the data from all subjects who are randomized to treatment and use any amount of the study treatment. Subjects will be analyzed according to the treatment they were assigned at randomization. Data obtained after discontinuation of treatment, but prior to withdrawal from the study, will be included in the ITT analysis set.
- The Modified Intent-to-Treat (mITT) analysis set is a subset of the ITT analysis set and is defined as the data from all subjects with post-randomization data obtained prior to discontinuation from treatment. Any data collected after completion of or discontinuation from randomized study medication will be excluded from the mITT analysis set but will still be included in the ITT analysis set. Subjects will be analyzed according to randomized treatment group. It is noted that a subject who used a study treatment, but took less than 1 full dose of treatment, will qualify for this analysis set. The mITT

analysis set will be the primary analysis set for all efficacy analyses. Note: The knowledge that a subject did not have an exacerbation constitutes an efficacy assessment.

- The Safety analysis set is defined as data from all subjects who are randomized to treatment and receive any amount of the study treatment. However, subjects will be analyzed according to treatment received rather than randomized. If a subject receives more than 1 randomized treatment, they will be analyzed and included in summaries according to the treatment they received the most. Subjects receiving no study treatment will be excluded, as will subjects who have no post-dose safety assessments. Note: The statement that a subject has no AEs also constitutes a safety assessment.
- The Holter Monitoring analysis set is defined as all subjects in the Safety analysis set who had at least 18 hours of acceptable quality Holter monitoring data at both Visit 3 (Holter Baseline) and Visit 7 (Week 12). Data judged to be impacted by major protocol deviations will be determined prior to database lock and excluded per the statistical protocol deviation plan.

9.3.2 Estimands

Three estimands are of interest in this trial:

- The primary estimand of interest is the Efficacy Estimand, defined as the effect of the randomized treatments in all subjects assuming continuation of randomized treatments for the duration of the study, regardless of actual compliance.
- The second estimand of interest is the Attributable Estimand, defined as the effect of treatment in subjects attributable to the randomized treatment. For this estimand, discontinuation of randomized treatment for reasons such as tolerability or lack of efficacy is considered a bad outcome.
- The third estimand of interest is the Treatment Policy Estimand, defined as the effect of randomized treatment over the study period regardless of whether randomized treatment is continued.

Analysis of the Efficacy Estimand will be conducted using the mITT analysis set where only data obtained prior to subjects discontinuing from randomized treatment will be utilized. This assumes that efficacy observed on treatment is reflective of what would have occurred after discontinuation of randomized treatment had they remained on treatment.

Analysis of the Attributable Estimand will be conducted in the mITT analysis set, but data that are missing due to treatment discontinuation will be imputed based on the 95th or the 5th percentile of the reference arm's distribution if the reason is reasonably attributable to tolerability or lack of efficacy. The 95th percentile would apply to an endpoint for which a higher value is a worse outcome, while the 5th percentile would apply to an endpoint for which a higher value is a better outcome. More detail about the computation of the Attributable Estimand will be provided in the SAP.

Analysis of the Treatment Policy Estimand will be conducted in the ITT analysis set, in which all observed data will be utilized regardless of whether subjects remain on randomized treatment.

9.4 Demographic and Baseline Characteristics

Demographic and baseline characteristics data will be summarized by treatment for the mITT and Safety analysis sets.

9.5 Efficacy Analysis

All efficacy assessments are relative to baseline. Baseline for spirometry endpoints will be defined as the mean of the 60- and 30-minute pre-dose values at the randomization visit. Though all possible comparisons will be performed, the key comparisons will be those between each dose of GP MDI with Placebo MDI and, for benchmarking purposes, Spiriva Respimat.

9.5.1 Primary Efficacy Analysis

The primary analysis will be conducted for the Efficacy Estimand where only data obtained prior to subjects discontinuing from study drug will be utilized. Analyses will also be conducted for the Attributable and Treatment Policy Estimands.

For the primary comparisons, the null hypothesis for each pair-wise comparison will be that the mean treatment difference is zero (mean treatment effects are equal). The alternative hypothesis is that the mean treatment difference is not zero (mean treatment effects are not equal). All p-values will be reported as 2-sided.

9.5.1.1 Change From Baseline in FEV₁ AUC₀₋₄

Change from baseline in FEV₁ AUC₀₋₄ will be analyzed using a linear repeated measures analysis of covariance (ANCOVA) model. The model will include treatment, visit, background fixed-dose ICS/LABA combination product, and treatment-by-visit interaction as categorical covariates and baseline FEV₁, percentage reversibility to ipratropium, and blood eosinophil count at screening as continuous covariates. An unstructured matrix will be used to model the variance-covariance structure. If this model fails to converge, an alternative structure will be employed as pre-specified in the SAP. Contrasts will be used to obtain estimates of the treatment differences at Week 24. Two-sided p-values and point estimates with 2-sided 95% confidence intervals will be produced for each treatment difference.

The FEV₁ AUC₀₋₄ will be calculated for the changes from baseline using the trapezoidal rule and will be normalized by dividing by the time (in hours) from dosing to the last measurement included (ie, 4 hours). For the Efficacy Estimand analysis, only 1 non-missing, post-dose value is required for the calculation of FEV₁ AUC₀₋₄. Actual time from dosing will be used in the calculation if available; otherwise, scheduled time will be used.

9.5.2 Secondary Efficacy Analysis

Similar to the primary efficacy analysis, the secondary efficacy analyses will be conducted for the Efficacy Estimand. Analyses will also be conducted for the Attributable and Treatment Policy Estimands.

9.5.2.1 Change From Baseline in Morning Pre-Dose Trough FEV₁

Change from baseline in morning pre-dose trough FEV₁ will be analyzed using a linear repeated measures ANCOVA model. The model will be similar to the one used for FEV₁ AUC₀₋₄. Contrasts will be used to obtain estimates of the treatment differences at Week 24. Two-sided p-values and point estimates with 2-sided 95% confidence intervals will be produced for each treatment difference.

9.5.2.2 Rate of Moderate/Severe Asthma Exacerbations

The ratio of the rates of moderate/severe asthma exacerbations will be analyzed with negative binomial regression. Asthma exacerbations will be considered separate events if more than 7 days are between the recorded stop date of the earlier event and start date of the later event. Time at risk of experiencing an exacerbation will be used as an offset variable in the model. Time during an exacerbation or in the 7 days following an exacerbation will not be included in the calculation of exposure. Treatments will be compared adjusting for baseline post-bronchodilator percent predicted FEV₁, baseline asthma exacerbation history, blood eosinophil count at screening, background ICS/LABA, and reversibility to ipratropium.

The number and percentage of subjects with exacerbations in each treatment group will be tabulated.

9.5.2.3 Change From Baseline in ACQ-7, ACQ-5, and AQLQ +12

Change from baseline in ACQ-7, ACQ-5, and AQLQ +12 will be analyzed using a linear repeated measures ANCOVA model. The model will include treatment, visit, background fixed-dose ICS/LABA combination product, and treatment-by-visit interaction as categorical covariates and baseline post-bronchodilator FEV₁ percent predicted, baseline score for the patient-reported outcome instrument, percentage reversibility to ipratropium, and blood eosinophil count at screening as continuous covariates. Contrasts will be used to obtain estimates of the treatment differences at Week 24. Two-sided p-values and point estimates with 2-sided 95% confidence intervals will be produced for each treatment difference.

9.5.3 Other Efficacy Analyses

Other efficacy analyses will be conducted for the Efficacy Estimand only.

9.5.3.1 Percentage of Responders in ACQ-5, ACQ-6, ACQ-7, and AQLQ +12

Responder analyses will be performed for ACQ-5, ACQ-6, ACQ-7, and AQLQ +12 at Week 24 and over the Treatment Period. Responders are defined as subjects with an

improvement of ≥ 0.5 points over baseline. Subjects who discontinue treatment for any reason will be classified as non-responders.

Logistic regression will be used to compare the treatment groups with background ICS/LABA as categorical covariates and baseline instrument score, blood eosinophil count at screening, percentage reversibility to ipratropium, and baseline post-bronchodilator percent predicted FEV₁ as continuous covariates. P-values and odds ratios with 95% confidence intervals will be produced for each treatment comparison.

9.5.3.2 Change from Baseline in ACQ-6

Change from baseline in ACQ-6 will be analyzed using a linear repeated measures ANCOVA model. The model will include treatment, visit, background fixed-dose ICS/LABA combination product, and treatment-by-visit interaction as categorical covariates and baseline post-bronchodilator FEV₁ percent predicted, baseline score for the patient-reported outcome instrument, percentage reversibility to ipratropium, and blood eosinophil count at screening as continuous covariates. Contrasts will be used to obtain estimates of the treatment differences at Week 24. Two-sided p-values and point estimates with 2-sided 95% confidence intervals will be produced for each treatment difference.

9.5.3.3 Time to First Asthma Exacerbation

Time to first moderate or severe asthma exacerbation will be analyzed with a Cox regression model to compare the treatment groups, adjusted for asthma exacerbation history, background ICS/LABA, reversibility to ipratropium, blood eosinophil count at screening, and baseline post-bronchodilator FEV₁ percent predicted.

Time to first severe asthma exacerbation and time to first exacerbation of any severity will each be analyzed in a manner similar to the analysis of time to first moderate or severe asthma exacerbation.

9.5.3.4 Rate of Severe Asthma Exacerbations or Exacerbations of Any Severity

Severe asthma exacerbations and asthma exacerbations of any severity will each be analyzed in a manner similar to the analysis of the rate of moderate/severe asthma exacerbations.

9.5.3.5 Peak FEV₁

Change from baseline in peak FEV₁ will be analyzed at each clinic visit using a linear repeated measures ANCOVA model. The model will be similar to the one used for the primary analyses.

9.5.3.6 Percentage of Symptom-Free Days, Rescue-Free Days, and Asthma Control Days

The percentages of symptom-free days, rescue-free days, and asthma control days will each be analyzed over the entire Treatment Period. Additionally, analyses will be conducted over each 4-week interval in the study. An ANCOVA model will be used with treatment, the

number of the relevant 4-week interval (interval 1 to 6), asthma exacerbation history, background ICS/LABA, and the treatment-by-4-week interval interaction as categorical covariates. Baseline percentage of endpoint days (where endpoint is symptom free, rescue free, or asthma control per model), baseline post-bronchodilator FEV₁ percent predicted, percentage reversibility to ipratropium, and blood eosinophil count at screening will be continuous covariates.

9.5.3.7 Rescue Medication Usage

The mean daily number of puffs of rescue medication use will be calculated overall and for each of the 4-week intervals during the Treatment Period. For every period of time for which the mean number of puffs of rescue medication will be calculated, missing values will be ignored in both the numerator and denominator. As such, the denominator will be adjusted based on the number of days (including half days) with non-missing values.

A linear repeated measures ANCOVA model will be used to analyze change from baseline in average daily rescue albuterol use. The model will include treatment, the number of the relevant 4-week interval (interval 1 to 6), asthma exacerbation history, background ICS/LABA, and the treatment-by-4-week interval interaction as categorical covariates and blood eosinophil count at screening, baseline daily rescue albuterol use, percentage reversibility to ipratropium, and baseline post-bronchodilator FEV₁ percent predicted as continuous covariates.

An unstructured variance-covariance matrix will be fit. If this model fails to converge, an alternative structure will be employed as pre-specified in the SAP. Contrasts will be used to obtain estimates of the treatment differences over 24 weeks. Two-sided p-values and point estimates with 2-sided 95% confidence intervals will be produced for each treatment difference.

9.5.3.8 Change From Baseline in Morning PEFr and Evening PEFr

Change from baseline in morning PEFr and evening PEFr will be analyzed over 4-week intervals using a linear repeated measures ANCOVA model.

9.5.3.9 F_{ENO}

Change from baseline in F_{ENO} will be analyzed using a linear repeated measures ANCOVA model. The model will be similar to the one used for the primary analyses.

Clinically meaningful increases and decreases from baseline in F_{ENO} will be summarized descriptively by visit. The clinically meaningful changes are defined below:

- A clinically meaningful increase in F_{ENO} is defined as an increase of 20% or more from baseline if the baseline is 50 parts per billion (ppb) or more or an increase of more than 10 ppb from baseline if the baseline is less than 50 ppb.

- A clinically meaningful decrease in F_{ENO} is defined as a decrease of 20% or more from baseline if the baseline value is 50 ppb or more or a decrease of more than 10 ppb from baseline if the baseline value is less than 50 ppb.

At each visit, the percentage of subjects with F_{ENO} less than 25 ppb, between 25 and less than 50 ppb, and at least 50 ppb will be summarized descriptively by treatment.

9.5.3.10 CompEx

Time to first CompEx event will be analyzed with a Cox regression model to compare the treatment groups adjusted for asthma exacerbation history, background ICS/LABA, reversibility to ipratropium, blood eosinophil count at screening, and baseline post-bronchodilator FEV_1 percent predicted. Subjects who do not experience a CompEx event will be censored at their Week 24 Visit.

9.5.4 Subgroup Analyses

Analyses of the primary, secondary, and other endpoints may be performed by various subgroups. In addition to baseline and demographic subgroups, other factors (T-helper cell type 2 high or low, GINA classification, etc) will be used to create subgroups of interest. All subgroup analyses will be described fully in the SAP.

9.5.5 Type I Error Control

The Type I error rate will be controlled within the primary and secondary efficacy analyses. As a general strategy, the Type I error rate will be strongly controlled within the primary analysis. The Type I error rate will also be controlled within the family of secondary analyses within a GP MDI treatment group.

Primary analysis testing will be conducted in descending dose order, with the highest dose of GP MDI tested against placebo at the nominal alpha. Testing will continue through the GP MDI doses as long as the results are successful. Testing will stop if any comparison of GP MDI versus placebo fails to meet statistical significance. Through this strategy, the Type I error rate of the primary analyses of all 3 GP MDI doses versus placebo will be strictly controlled to the nominal alpha.

The secondary analyses for each dose of GP MDI versus placebo will proceed only if the primary analysis for that GP MDI dose is successful. The Type I error rate within the secondary analyses of each GP MDI dose versus placebo will be controlled with a multiple comparison procedure as specified in the SAP.

9.6 Safety Analysis

9.6.1 AEs

Adverse events during the Treatment Period will be summarized by the number of subjects experiencing an event. Adverse events will be tabulated at the level of the Medical Dictionary for Regulatory Activities (MedDRA) system organ class and preferred term. The version of MedDRA current at the time of database lock will be used in the tabulations and listings. Tabulations will be broken down by severity, seriousness, AEs leading to discontinuation, and by relationship to study drug. No hypothesis tests will be performed.

9.6.2 AESIs

The AESIs will be tabulated by treatment group. Additional analyses may be performed and will be detailed in the SAP.

9.6.3 Clinical Laboratory Measurements

Summary statistics (mean, median, standard deviation [SD], and range) of change from baseline values will be tabulated for each treatment and each assessment time. For clinical laboratory measurements, baseline will be defined as the last available value prior to randomization. Potentially clinically significant values will be identified and summarized.

9.6.4 Vital Signs

Summary statistics (mean, median, SD, and range) of change from baseline will be tabulated by vital sign parameter and treatment for each scheduled assessment time. For vital signs, baseline will be defined as the average of the values prior to dosing on the day of randomization. In addition, potentially clinically significant values will be identified and summarized.

9.6.5 ECGs

Summary statistics (mean, median, SD, and range) for absolute values and change from baseline will be tabulated by ECG parameter and treatment for each scheduled assessment time. For ECG parameters, baseline values will be defined as the last value obtained prior to randomization. In addition, potentially clinically significant values will be identified and summarized.

9.6.6 24-Hour Holter Monitoring

Holter monitoring endpoints are listed in Section 3.5.

Change from baseline in the ventricular and supraventricular variables will be analyzed with nonparametric methods. The Wilcoxon Rank Sum Test will be used to produce p-values for the pairwise comparison of treatments. The median treatment differences will be presented with 95% confidence intervals based on the Hodges-Lehmann approach. The number of

subjects experiencing a ventricular couplet, ventricular run, supraventricular couplet, and supraventricular run at Week 12 will be analyzed with a logistic regression model. Alternative analysis methods may be employed if found to be appropriate and will be pre-specified in the SAP.

Additionally, for the endpoints that involve incidences and proportions of events, those values will be summarized by treatment.

9.7 Sample Size Consideration

A sample size of 1125 subjects (250 subjects per double-blind treatment group, 125 subjects in the open-label Spiriva Respimat treatment group) will provide approximately 93% power to detect a 120 mL difference between the GP MDI treatment groups and Placebo MDI in the analysis of change from baseline in FEV₁ AUC₀₋₄ at Week 24. The assumed SD is 348 mL at each visit. The 2-sided alpha for each pairwise comparison is 0.05.

Comparisons of GP MDI to Spiriva Respimat will be focused on estimation as the study is not formally powered to demonstrate non-inferiority or superiority.

For the secondary endpoint of change from baseline in morning pre-dose trough FEV₁ at Week 24, it is assumed that the difference between GP MDI and Placebo MDI is 90 mL, with each treatment group having an SD of 317 mL at each visit. Under these assumptions, the study will have 80% power to declare GP MDI superior to Placebo MDI in the analysis of change from baseline in morning pre-dose trough FEV₁ at Week 24.

The Type I error rate will be strongly controlled for the primary analyses. The Type I error control strategy for the primary and secondary analyses are described in Section 9.5.5. This sample size assumes that approximately 20% of randomized subjects will have discontinued study drug prior to Week 24.

9.8 Data Validation and Transformation

In general, the distribution of spirometry measures is well approximated by a normal distribution. Under some circumstances, however, extreme and atypical values can arise. Such values have high influence on estimation of variance parameters and on standard errors of fixed effect estimates. The distribution of residuals and influence statistics will be examined to identify such cases prior to unblinding. In the event that a single or small number of such outlying values are found to exist and found to be highly influential, the effects may be ameliorated either by transformation or by removal of the outlier.

Transformations to be considered may include the logarithmic transformation, or normal rank transformations. Any changes will be documented prior to unblinding and, where outliers are removed, sensitivity analyses including those values will be reported. Changes in spirometry measures from baseline, and from time point to time point will be examined graphically before data base lock, and before unblinding, as part of data quality management.

9.9 Analysis Plan

All analyses will be specified in a detailed SAP that will include table and data listing shells with mock graphical representations. The SAP will be signed before database lock and unblinding.

9.10 Blinded Sample Size Re-Estimation

No blinded sample size re-estimation is currently planned for this study.

9.11 Interim Analysis

No interim analysis is currently planned for this study.

9.12 Handling of Missing Data

Sensitivity analyses will evaluate the robustness of findings to missing data. Details will be provided in the SAP.

9.13 Statistical Software

Data processing, statistical screening, descriptive reporting and analysis of the efficacy and safety data will be performed using SAS[®] (Version 9.2 or higher). Graphs may also be produced using R[®] (R. Development Core Team, 2003).

10 ADMINISTRATIVE CONSIDERATIONS

10.1 Regulatory Authority Approval

The Sponsor will obtain approval to conduct this study from the appropriate regulatory agency in accordance with any applicable country-specific regulatory requirements prior to initiating this study in a given country.

10.2 Ethical Conduct of the Study and IRB or IEC Approval

This study is to be conducted in accordance with Good Clinical Practice (GCP). These standards respect the following guidelines:

- Guideline for Good Clinical Practice E6 (R1): Consolidated Guideline (ICH, May 1996).
- US CFR dealing with clinical studies (21 CFR parts 50, 54, 56, and 312).
- Declaration of Helsinki, concerning medical research in humans (Ethical Principles for Medical Research Involving Human Subjects)
- Any additional regulatory requirements.

The Investigator (or the Sponsor, where applicable) is responsible for ensuring that this protocol, the site's ICF, and any other information that will be presented to potential subjects (eg, advertisements or information that supports or supplements the ICF) are reviewed and approved by the appropriate IRB/IEC. The Investigator agrees to allow the IRB/IEC direct access to all relevant documents. The IRB/IEC must be constituted in accordance with all applicable regulatory requirements.

The Sponsor will provide the Investigator with relevant document(s)/data necessary for IRB/IEC review of the study. If the protocol, the ICF, or any other information that the IRB/IEC has approved for presentation to potential subjects is amended during the study, the Investigator is responsible for ensuring the IRB/IEC reviews and approves, when applicable, these amended documents. The Investigator must follow all applicable regulatory requirements pertaining to the use of an amended ICF including obtaining IRB/IEC approval of the amended form before new subjects consent to take part in the study. The approval of an amended ICF/other information by an IRB/IEC must be promptly forwarded to the Sponsor or its designee.

10.3 Subject Informed Consent

This study will be conducted in accordance with applicable subject privacy requirements. The proposed ICF, which must be in compliance with applicable regulations, must be reviewed and approved by the IRB/IEC and the Sponsor prior to initiation of the study.

The Investigator will be responsible for obtaining written informed consent from potential subjects prior to any study-specific screening procedures. For subjects <18 years of age, an

assent form will be signed by the subject, and a parent or legal guardian will sign the ICF. A copy of the signed ICF and assent form (where applicable) will be provided to the subject and the original will be retained by the Investigator.

10.4 Laboratory Accreditation

Any laboratory facility intended to be used for analysis of clinical laboratory samples required by this protocol must provide evidence of adequate licensure or accreditation according to the prevailing regulations in that state and/or country. Reference values and/or normal ranges for the test results must be provided to the Sponsor. The Sponsor must be notified promptly in writing of any changes occurring in reference values during the course of the study.

10.5 Confidentiality

10.5.1 Confidentiality of Data

By signing this protocol, the Investigator affirms that information furnished to the Investigator by the Sponsor will be maintained in confidence. Information relating to this study will be divulged to an IRB/IEC or similar expert committee, affiliated institution, or employees only under an appropriate understanding of confidentiality with said person(s). Data generated by this study will be considered confidential by the Investigator except to the extent that it is included in a publication.

10.5.2 Confidentiality of Subject Records

By signing this protocol, the Investigator agrees that the Sponsor (or its representative), IRB/IEC, or regulatory agency representatives may consult and/or copy study documents in order to verify worksheet/eCRF data. By signing the ICF, the subject (or parent or legal guardian, as applicable) agrees to this process. If study documents are photocopied during the process of verifying worksheet/eCRF information, the subject will be identified by a unique code; full names/initials will be masked prior to transmission to the Sponsor. In addition, the Investigator agrees to treat all subject data used and disclosed in connection with this study in accordance with all applicable privacy laws (ie, Health Insurance Portability and Accountability Act), rules and regulations.

10.6 Quality Control and Assurance

The Sponsor is responsible for implementing and maintaining quality control and quality assurance systems with written Standard Operating Procedures to ensure that studies are conducted and data are generated, documented, and reported in compliance with the protocol, accepted standards of GCP, and all applicable federal, state, and local laws, rules and regulations relating to the conduct of a clinical study.

10.7 Data Management

Data management procedures and information for this protocol will be provided by the Sponsor.

10.8 Study Monitoring

In accordance with applicable regulations, GCP, and the Sponsor's procedures, clinical monitors will contact the site prior to subject enrollment to review the protocol and data collection procedures with site staff. In addition, the monitor will periodically contact the site, including conducting on-site visits. The extent, nature, and frequency of on-site visits will be based on the study objective and/or endpoints, the purpose of the study, study design complexity and enrollment rate.

During these contacts, the monitor will:

- Check the progress of the study
- Review study data collected
- Conduct source document verification
- Identify any issues and address their resolution

These reviews will be done in order to verify that the:

- Data are authentic, accurate, and complete
- Safety and rights of subjects are being protected
- Study is conducted in accordance with the currently approved protocol (and any amendments), GCP, and all applicable regulatory requirements

The Investigator agrees to allow the monitor direct access to all relevant documents and to allocate his/her time and the time of his/her staff to the monitor to discuss findings and any relevant concerns. Upon completion of the study, the monitor will conduct the following activities in conjunction with the Investigator or site staff, as appropriate:

- Return of all study data to the Sponsor
- Data queries
- Accountability, reconciliation, and arrangements for unused investigational product(s)
- Review of site study records for completeness

After the final review of the study files, the files should be secured for the appropriate time period as specified in Section 10.9. The Investigator will also permit inspection of the study

files by the Sponsor's Quality Assurance auditors, or designees, including other representatives from the Sponsor, and authorized representatives of the Food and Drug Administration (FDA) or other applicable regulatory agencies.

10.9 Retention of Data

Documents that individually and collectively permit evaluation of the conduct of the study and the quality of the data produced must be maintained for review by the Sponsor's Quality Assurance auditors and by all applicable regulatory authorities. The period of time these documents must be maintained is governed by county-specific regulations. The Sponsor or its designee will inform the Investigator when these documents may be destroyed. The Sponsor or its designee must be notified in writing at least 6 months prior to the intended date of disposal of any study-related documents to allow the Sponsor to make alternate storage arrangements.

10.10 Financial Disclosure

The Principal Investigator or sub-Investigators named on FDA Form 1572 will need to complete a financial disclosure form prior to study initiation, at any time during the study if new information needs to be disclosed, and for 1 year after study completion. Investigators should make the IRB/IEC aware of any financial interests that the Investigator has in the investigational product.

10.11 Investigator's Final Report

Following completion of the study, the Investigator will submit a final written report to the Sponsor.

10.12 Publication and Disclosure Policy

The Sponsor intends to publish the results of all the clinical studies that it sponsors in compliance with the Declaration of Helsinki. Consistent with the recommendations of the editors of several leading medical journals, the International Committee of Medical Journal Editors (ICMJE), authorship of publications resulting from sponsored studies should fairly recognize the activities of those that have made a significant contribution to the study. In addition, the Sponsor recognizes and adheres to the precepts of the International Society for Medical Publications Professionals (ISMPP), which provides guidance to the preparation of publications, disclosure of conflicts of interest, and the protection of intellectual property. Thus, it is anticipated that authorship will reflect the contribution made by the Sponsor's personnel, the investigators, and others involved, such as statisticians.

In recent years, issues about conflicts of interest and accuracy of the study data have been raised in the medical press. Accordingly, the Sponsor has developed publication guidelines as described below:

1. **Responsibility:** Each principal Investigator is responsible for the accuracy and completeness of all data from their site. The Sponsor (or its representatives) is

responsible for the accuracy of the data entered into the study databases and for the accuracy of the analyses conducted.

2. **Authorship and Publication Committee:** The Sponsor, in collaboration with the Investigators, will establish the appropriate authorship and responsibility for drafting study documents in accordance with the principles of the ICMJE and ISMPP. It is anticipated that a publication committee will be formed to assume oversight of these activities. All manuscripts will be reviewed and agreed upon before submission for publication by all authors.
3. **Sponsor Review of External Manuscripts:** Consistent with the first bullet point, drafts of any and all publications or presentations that may arise from this study must be submitted at least 30 days prior to submission for publication or presentation to the Sponsor for review, approval, and to ensure consistency with the policy in this protocol. The Sponsor will have the right to request appropriate modification to correct facts and to represent its opinions, or the opinions of the publication committee, if these differ with the proposed publication.
4. **Confidentiality:** Investigators will conduct all interactions with the Sponsor and with third parties consistent with the executed confidentiality agreements. While publication, by intention, presents the critical scientific data in a public forum, some information (such as future plans, results of nonclinical studies, or chemical formulae) may still need to remain confidential.
5. **Medical Journal Review:** Consistent with the intention of the Sponsor to publish the study in a fair and accurate manner, the Sponsor supports diligence in the publication review process of medical journals. Accordingly, upon request, all pertinent study data and information will be made available as supplemental information for journal editors and reviewers to evaluate and audit, eg, protocol and amendments, data tabulations, etc. The journal and reviewers will need to make arrangements to maintain the confidentiality of such supplemental information, where relevant, and the Sponsor will make suitable arrangements to ensure that the identity of journal reviewers is kept confidential. Records will be maintained of reviewers and the respective documents and datasets that were reviewed by each of them.
6. **Reporting of Clinical Trials Results:** To provide transparency in the conduct and reporting of randomized clinical trials, the Sponsor reports clinical findings based on the guidance of The CONSolidated Standards of Reporting Trials Statement (Moher 2012) and a 25-item checklist that is intended to improve the reporting of a randomized controlled trial, facilitate reader understanding of the trial design, conduct, analysis and interpretation, and to support their ability to assess the validity of its results.
7. **Internet Clinical Trial Listing:** In addition, also consistent with the recommendations of the ICMJE, the Sponsor will make available appropriate information regarding the study via the internet. This will include registration and listing of the study on www.clinicaltrials.gov, the US National Institutes of Health listing of clinical trials.

11 REFERENCE LIST

- Barnes PJ. Triple inhalers for obstructive airways disease: will they be useful? *Expert Rev Respir Med.* 2011; 5(3):297-300.
- Dweik RA, Boggs PB, Erzurum SC, et al. An official ATS clinical practice guideline: interpretation of exhaled nitric oxide levels (FeNO) for clinical applications. *Am J Resp Crit Care Med.* 2011;184(5):602-615.
- Global Initiative for Asthma (GINA). Global Strategy for Asthma Management and Prevention, 2017. <http://ginasthma.org/>. Accessed 17 September 2017.
- Juniper EF, Svensson K, Mörk AC, Ståhl E. Modification of the asthma quality of life questionnaire (standardised) for patients 12 years and older. *Health Qual Life Outcomes.* 2005;3:58.
- Juniper EF, O’Byrne PM, Guyatt GH, Ferrie PJ, King DR. Development and validation of a questionnaire to measure asthma control. *Eur Respir J.* 1999;14(4):902-907.
- Juniper EF, Buist AS, Cox FM, Ferrie PJ, King DR. Validation of a standardized version of the Asthma Quality of Life Questionnaire. *Chest.* 1999; 115(5):1265-1270.
- Juniper EF, Guyatt GH, Willan A, Griffith LE. Determining a minimal important change in a disease-specific Quality of Life Questionnaire. *J Clin Epidemiol.* 1994;47(1):81-87.
- Juniper EF, Guyatt GH, Ferrie PJ, Griffith LE. Measuring quality of life in asthma. *Am Rev Respir Dis.* 1993;147(4):832-838.
- Juniper EF, Guyatt, GH, Epstein RS, Ferrie PJ, Jaeschke R, Hiller TK. Evaluation of impairment of health-related quality of life in asthma: development of a questionnaire for use in clinical trials. *Thorax.* 1992;47(2):76-83.
- Kerstjens HA, Casale TB, Bleecker E, et al. Tiotropium or salmeterol as add-on therapy to inhaled corticosteroids for patients with moderate symptomatic asthma: two replicate, double-blind, placebo-controlled, parallel-group, active-comparator, randomised trials. *Lancet Respir Med.* 2015;3(5):367-376.
- Kerstjens HA, Engel M, Dahl R, et al. Tiotropium in asthma poorly controlled with standard combination therapy. *N Engl J Med.* 2012;367(13):1198-1207.
- Levey AS, Stevens LA, Schmid CH, et al. A new equation to estimate glomerular filtration rate. *Ann Intern Med.* 2009;150(9):604-612.
- Miller MR, Hankinson J, Brusasco V, et al. Standardisation of spirometry. *Eur Respir J.* 2005;26(2):319-338.

Moher D, Hopewell S, Schulz KF, et al. CONSORT 2010 explanation and elaboration: Updated guidelines for reporting parallel group randomised trials. *Int J Surg*. 2012;10(1):28-55.

Reddel HK, Taylor DR, Bateman ED, et al. An official American Thoracic Society/European Respiratory Society statement: asthma control and exacerbations: standardizing endpoints for clinical asthma trials and clinical practice. *Am J Respir Crit Care Med*. 2009;180(1):59-99.

Schwartz GJ, Brion LP, Spitzer A. The use of plasma creatinine concentration for estimating glomerular filtration rate in infants, children, and adolescents. *Pediatr Clin North Am*. 1987;34(3):571-590.

SPIRIVA RESPIMAT (tiotropium bromide) inhalation spray, for oral inhalation [package insert]. Ridgefield, CT: Boehringer Ingelheim Pharmaceuticals, Inc.; Feb 2017.

12 APPENDICES

Appendix 1 Body Mass Index Calculators

The online calculators below should be used to determine a subject's body mass index (BMI) from their height and weight. Height and weight can be measured in either English units (feet, inches, pounds) or metric units (centimeters, kilograms).

- For children/teens aged 2 to <20 years:
<https://nccd.cdc.gov/dnpabmi/Calculator.aspx>
- For adults 20 years of age and older:
https://www.cdc.gov/healthyweight/assessing/bmi/adult_BMI/english_bmi_calculator/bmi_calculator.html

Appendix 2 Spirometry Assessment Criteria

Acceptable Versus Usable Tests

Acceptable Tests must meet the following 7 Criteria:

1. Acceptable start of exhalation with brisk upstroke, no hesitation or false start, and back extrapolation volume (EV) <5% of forced vital capacity (FVC) or 0.150 L, whichever is the greater. (Refer to example in Figure A1-1)
2. No cough during the first second.
3. No valsalva maneuver.
4. No leak.
5. No obstruction of mouthpiece.
6. No extra breaths.
7. Plateau achieved, ie, the volume-time curve shows no change in volume (<0.025 L) for ≥ 1 second, and the patient has tried to exhale for at least 6 seconds.

An acceptable test meets all 7 criteria listed. This is to be considered the “gold standard”.

Usable spirometry tracings are those that only meet criteria 1 and 2 (Figure A1-1). When this occurs, repeat testing up to 8 attempts in an effort to obtain 3 acceptable spirograms. If only usable tests are obtained, report results based on the 3 best usable results with observed limitations.

Figure A1-1. Example of a Usable Spirogram

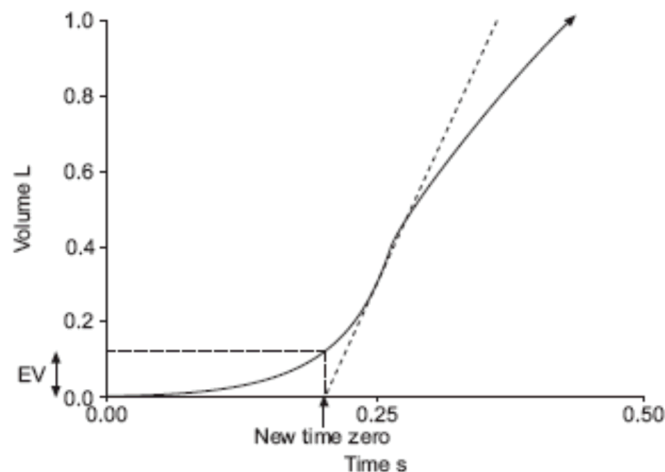

The expanded version of the early part of a subject’s volume-time spirogram, illustrating back-extrapolation through the steepest part of the curve, where flow is peak expiratory flow (PEF), to determine the new “time zero”. Forced vital capacity (FVC) -4.291 L; back-extrapolated volume (EV) – 0.123 L (2.9% FVC); back-extrapolation line through PEF.

Between-Maneuver Repeatability Criteria

After 3 acceptable spirograms have been obtained, apply the following tests

- The 2 largest values of FVC must be within 0.150 L of each other
- The 2 largest values of FEV₁ must be within 0.150 L of each other

If these criteria are met, the spirometry testing for that time-point may conclude. The highest FEV₁ and the highest FVC obtained at each testing time-point (even if from different repeatability tracings), will be collected.

If acceptability criteria are not met, continue testing until they are met or the patient cannot/should not continue (maximum of 8 attempts).

Appendix 3 Spirometry Performance Recommendations

Spirometry data of the highest quality must be obtained for proper interpretation of the results of this protocol. To these ends, a standard spirometer will be used (provided by Pearl), central training provided, qualification will be required, and specific operating instruction will also be provided.

The following instructions are supported by ATS/ERS defined criteria (Miller 2005).

FEV₁ AND FVC MANEUVERS

Equipment Requirements

The spirometer must be capable of accumulating volume for ≥ 15 s (longer times are recommended) and measuring volumes of ≥ 8 L (body temperature (ie, 37°C), ambient pressure, saturated with water vapor, body temperature and pressure saturated [BTPS]) with an accuracy of at least $\pm 3\%$ of reading or ± 0.050 L, whichever is greater, with flows between 0 and 14 L·s⁻¹. The total resistance to airflow at 14.0 L·s⁻¹ must be < 1.5 cmH₂O L⁻¹ 1s⁻¹ (0.15 kPa L⁻¹ 1s⁻¹). The total resistance must be measured with any tubing, valves, pre filter, etc. included that may be inserted between the subject and the spirometer. Some devices may exhibit changes in resistance due to water vapor condensation, and accuracy requirements must be met under BTPS conditions for up to 8 successive forced vital capacity (FVC) maneuvers performed in a 10-minute period without inspiration from the instrument.

Display

For optimal quality control, both flow volume and volume time displays are useful, and test operators should visually inspect the performance of each maneuver for quality assurance before proceeding with another maneuver. This inspection requires tracings to meet the minimum size and resolution requirements set forth in this standard. Displays of flow vs. volume provide more detail for the initial portion (first 1 s) of the FVC maneuver. Since this portion of the maneuver, particularly the peak expiratory flow rate, is correlated with the pleural pressure during the maneuver, the flow–volume display is useful to assess the magnitude of effort during the initial portions of the maneuver. The ability to overlay a series of flow–volume curves registered at the point of maximal inhalation may be helpful in evaluating repeatability and detecting sub maximal efforts. However, if the point of maximal inhalation varies between blows, then the interpretation of these results is difficult because the flows at identical measured volumes are being achieved at different absolute lung volumes. In contrast, display of the FVC maneuver as a volume–time graph provides more detail for the latter part of the maneuver. A volume–time tracing of sufficient size also allows independent measurement and calculation of parameters from the FVC maneuvers. In a display of multiple trials, the sequencing of the blows should be apparent to the user. For the start of test display, the volume–time display should include > 0.25 s, and preferably 1 s, before exhalation starts (zero volume). This time period before there is any change in volume is needed to calculate the back extrapolated volume (EV) and to evaluate effort during the initial portion of the maneuver. Time zero, as defined by EV, must be presented as the zero

point on the graphical output. The last 2 s of the maneuver should be displayed to indicate a satisfactory end of test.

When a volume–time curve is plotted as hardcopy, the volume scale must be $\geq 10 \text{ mm L}^{-1}$ (BTPS). For a screen display, 5 mm L^{-1} is satisfactory (Table A2-1).

Table A2-1. Recommended Minimal Scale Factors for Time, Volume and Flow on Graphical Output

Parameter	Instrument Display		Hardcopy Graphical Output
	Resolution Required	Scale Factor	Resolution Required
Volume*	0.050 L	5 mm-L ⁻¹	0.050 L
Flow*	0.200 L-s ⁻¹	2.5 mm L ⁻¹ s ⁻¹	0.200 L-s ⁻¹
Time	0.2 s	10 mm-s ⁻¹	0.2 s

*The correct aspect ratio for flow versus volume display is two units of flow per one unit of volume

The time scale should be $\geq 20 \text{ mm-s}^{-1}$, and larger time scales are preferred ($\geq 30 \text{ mm-s}^{-1}$) when manual measurements are made. When the volume–time plot is used in conjunction with a flow–volume curve (ie, both display methods are provided for interpretations and no hand measurements are performed), the time scale requirement is reduced to 10 mm-s^{-1} from the usually required minimum of 20 mm-s^{-1} (Table A2-1). The rationale for this exception is that the flow–volume curve can provide the means for quality assessment during the initial portion of the FVC maneuver. The volume–time curve can be used to evaluate the latter part of the FVC maneuver, making the time scale less critical.

Validation

It is strongly recommended that spirometry systems should be evaluated using a computer driven mechanical syringe or its equivalent, in order to test the range of exhalations that are likely to be encountered in the test population. Testing the performance of equipment is not part of the usual laboratory procedures.

Quality Control

Attention to equipment quality control and calibration is an important part of Good Laboratory Practice. At a minimum, the requirements are as follows: 1) a log of calibration results is maintained; 2) the documentation of repairs or other alterations which return the equipment to acceptable operation; 3) the dates of computer software and hardware updates or changes; and 4) if equipment is changed or relocated (eg, industrial surveys), calibration checks and quality control procedures must be repeated before further testing begins.

Key aspects of equipment quality control are summarized in Table A2-2.

Table A2-2. Summary of Equipment Quality Control

Test	Minimal Interval	Action
Volume	Daily	Calibration check with a 3 L syringe
Leak	Daily	2 cmH ₂ O (0.3 kPa) constant pressure for 1 minute
Volume Linearity	Quarterly	1 L increments with a calibrating syringe measured over the entire volume range
Flow Linearity	Weekly	Test at least three different flow ranges
Time	Quarterly	Mechanical recorder check with stop watch
Software	New versions	Log installation date and perform test using “known” subject

Calibration is the procedure for establishing the relationship between sensor determined values of flow or volume and the actual flow or volume. A calibration check is different from calibration and is the procedure used to validate that the device is within calibration limits, eg, $\pm 3\%$ of true. If a device fails its calibration check, then new calibration procedure or equipment maintenance is required. Calibration checks must be undertaken daily, or more frequently, if specified by the manufacturer. The syringe used to check the volume calibration of spirometers must have an accuracy of ± 15 mL or $\pm 0.5\%$ of the full scale (15 mL for a 3 L syringe), and the manufacturer must provide recommendations concerning appropriate intervals between syringe calibration checks. Users should be aware that a syringe with an adjustable or variable stop may be out of calibration if the stop is reset or accidentally moved. Calibration syringes should be periodically (eg, monthly) leak tested at more than one volume up to their maximum; this can be done by attempting to empty them with the outlet corked. A dropped or damaged syringe should be considered out of calibration until it is checked.

With regard to time, assessing mechanical recorder time scale accuracy with a stopwatch must be performed at least quarterly. An accuracy of within 2% must be achieved.

Quality Control for Volume Measuring Devices

The volume accuracy of the spirometer must be checked at least daily, with a single discharge of a 3 L calibrated syringe. Daily calibration checking is highly recommended so that the onset of a problem can be determined within 1 day and also to help define day to day laboratory variability. More frequent checks may be required in special circumstances, such as: 1) during industrial surveys or other studies in which a large number of subject maneuvers are carried out, the equipment’s calibration should be checked more frequently than daily; and 2) when the ambient temperature is changing (eg, field studies), volume accuracy must be checked more frequently than daily and the BTPS correction factor appropriately updated.

The accuracy of the syringe volume must be considered in determining whether the measured volume is within acceptable limits. For example, if the syringe has an accuracy of 0.5%, a reading of $\pm 3.5\%$ is appropriate.

The calibration syringe should be stored and used in such a way as to maintain the same temperature and humidity of the testing site. This is best accomplished by keeping the syringe in close proximity to the spirometer, but out of direct sunlight and away from heat sources.

Volume type spirometer systems must be evaluated for leaks every day. The importance of undertaking this daily test cannot be overstressed. Leaks can be detected by applying a constant positive pressure of ≥ 3.0 cmH₂O (0.3 kPa) with the spirometer outlet occluded (preferably at or including the mouthpiece). Any observed volume loss of 0.30 mL after 1 minute indicates a leak and needs to be corrected.

At least quarterly, volume spirometers must have their calibration checked over their entire volume range using a calibrated syringe or an equivalent volume standard. The measured volume should be within $\pm 3.5\%$ of the reading or 65 mL, whichever is greater. This limit includes the 0.5% accuracy limit for a 3-L syringe. The linearity check procedure provided by the manufacturer can be used if it is equivalent to one of the following procedures:

- 1) consecutive injections of 1-L volume increments while comparing observed volume with the corresponding cumulative measured volume (eg, 0–1, 1–2, 2–3, ... 6–7 and 7–8 L, for an 8-L spirometer); and
- 2) injection of a 3-L volume starting at a minimal spirometer volume, then repeating this with a 1-L increment in the start position (eg, 0–3, 1–4, 2–5, 3–6, 4–7, and 5–8 L, for an 8-L spirometer). The linearity check is considered acceptable if the spirometer meets the volume accuracy requirements for all volumes tested.

Quality Control for Flow Measuring Devices

With regards to volume accuracy, calibration checks must be undertaken at least daily, using a 3-L syringe discharged at least three times to give a range of flows varying between 0.5 and 12 L·s⁻¹ (with 3-L injection times of 6 s and 0.5 s). The volume at each flow should meet the accuracy requirement of $\pm 3.5\%$. For devices using disposable flow sensors, a new sensor from the supply used for subject tests should be tested each day.

For linearity, a volume calibration check should be performed weekly with a 3-L syringe to deliver three relatively constant flows at a low flow, then three at a mid-range flow and finally three at a high flow. The volumes achieved at each of these flows should each meet the accuracy requirement of $\pm 3.5\%$.

VITAL CAPACITY AND INSPIRATORY CAPACITY MANEUVERS

Equipment

For measurements of vital capacity (VC) and inspiratory capacity, the spirometer or flow meter must comply with the requirements for FVC (as described previously) and be capable of accumulating volume for >30 s. Expiratory maneuvers or, ideally, both inspiratory and

expiratory maneuvers should be included in the display of VC maneuver. Regardless of whether the inspiratory or expiratory maneuver is used for deriving measurements, a display of the entire recorded VC maneuver must be provided. The maximal expiratory volume must be assessed to determine whether the subject has obtained a plateau in the expiratory effort. For display of the slow VC, the time scale may be reduced to 5 mm-s⁻¹.

TECHNICAL CONSIDERATIONS

Minimal Recommendations for Spirometry Systems

Accurate results require accurate equipment. Spirometer equipment recommendations apply to all spirometers and are minimal requirements. In some circumstances, it may be appropriate to exceed these requirements (ie, in some research/surveillance applications). Instrumentation recommendations should be followed to provide accurate spirometric data and information that is comparable from laboratory to laboratory and from one time period to another. The accuracy of a spirometry system depends on characteristics of the entire system, from the volume or flow transducer and the use of an in line filter, to the recorder, display or processor. Changes in any aspect of the equipment or errors at any step in the process can affect the accuracy of the results. For example, if the BTPS correction factor is wrong, an accurately measured FVC will be incorrectly reported. Spirometers are not required to measure all of the indices in Table A2-3, but must meet the recommendations for those that are measured. Accuracy and repeatability recommendations apply over the entire volume range of the instrument.

Table A2-3. Range and Accuracy Recommendations Specified for Forced Expiratory Maneuvers

Test	Range/Accuracy (BTPS)	Flow Range (L-s ⁻¹)	Resistance and Back Pressure	Test Signal
VC	0.5–8 L, ±3% of reading or ±0.050 L, whichever is greater	0-14		3-L Calibration syringe
FVC	0.5–8 L, ±3% of reading or ±0.050 L, whichever is greater	0-14	<1.5 cmH ₂ O L ⁻¹ s ⁻¹ (0.15 kPa L ⁻¹ s ⁻¹)	24 ATS waveforms, 3-L Cal Syringe
FEV ₁	0.5–8 L, ±3% of reading or ±0.050 L, whichever is greater	0-14	<1.5 cmH ₂ O L ⁻¹ s ⁻¹ (0.15 kPa L ⁻¹ s ⁻¹)	24 ATS waveforms
Time Zero	The time point from which all FEV _t measurements are taken		Back extrapolation	

FEV_t: forced expiratory volume in t seconds















BTPS Correction

All spirometry values should be reported at BTPS by any method (measuring temperature and barometric pressure) proven effective by the manufacturer. For volume-type spirometers, the temperature inside the spirometer should be measured for each breathing maneuver.

Regardless of the BTPS correction technique used, the ambient temperature must always be recorded with an accuracy of $\pm 1^{\circ}\text{C}$. In situations where the ambient air temperature is changing rapidly ($>3^{\circ}\text{C}$ in <30 min), continuous temperature corrections may be necessary. Spirometer users should be aware of potential problems with testing performed at lower ambient temperatures: 17°C is the lower limit for ambient temperature, unless a manufacturer states that their spirometer will operate accurately at lower ambient temperatures. If barometric pressure is not used in calculating the BTPS correction factor, the range of barometric pressures over which the BTPS correction factor is valid must be published.

Appendix 4 Dose-Indicator Reading for GP MDI and Placebo MDI

For the purposes of this study, when recording the dose indicator display value, review the indicator display at the top of the MDI and record the number of inhalations remaining that matches the chart below:

130 Count (Actuation) Version Shown				
 <p>If your dose indicator display looks like this record 120+</p>	 <p>If your dose indicator display looks like this record 120</p>	 <p>If your dose indicator display looks like this record 110</p>	 <p>If your dose indicator display looks like this record 100</p>	 <p>If your dose indicator display looks like this record 90</p>
 <p>If your dose indicator display looks like this record 80</p>	 <p>If your dose indicator display looks like this record 70</p>	 <p>If your dose indicator display looks like this record 60</p>	 <p>If your dose indicator display looks like this record 50</p>	 <p>If your dose indicator display looks like this record 40</p>
 <p>If your dose indicator display looks like this record 30</p>	 <p>If your dose indicator display looks like this record 20</p>	 <p>If your dose indicator display looks like this record 10</p>	 <p>If your dose indicator display looks like this record 0</p>	

Appendix 5 Instructions for Use of GP MDI and Placebo MDI

How do I store the inhaler?

- The inhaler should be stored below 25°C (77°F) in a dry place. Excursions permitted up to 30°C (86°F).
- The contents of the canister are under pressure. Do not puncture or throw the canister into a fire or incinerator. Do not use or store it near heat or open flame. Storage above 120°F may cause the canister to burst.
- **Keep the product and all medicines out of the reach of children.**

For Oral Inhalation Only

Parts of the Inhaler:

- The parts of your inhaler are seen in **Figure A4-1**.

Figure A4-1

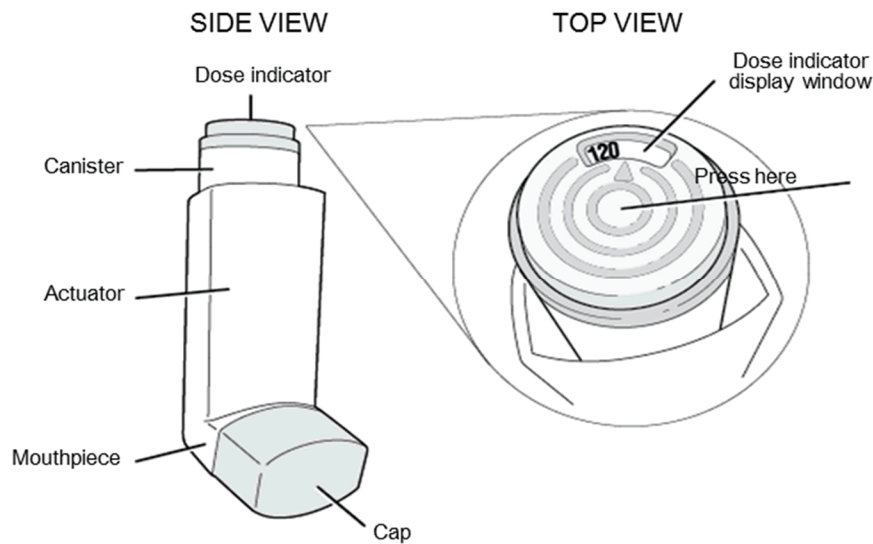

- The **Dose indicator** lets you know about how many puffs are left in your inhaler and is the part of the inhaler that is pressed to dispense a puff of medication. **See Figure A4-1.**
- The **Dose indicator** should be pointing just to the right of 120 when your inhaler is new. **See Figure A4-1.**
- The **Dose indicator** has numbers for every 20 puffs. The **Dose indicator** display will move after every tenth puff.

- For example, if the **Dose indicator** is pointing to 120 (see **Figure A4-2a**) and you take 10 puffs it will move between 120 and 100. This means that there are 110 puffs of medicine left (see **Figure A4-2b**). After 10 more puffs are used, the **Dose indicator** pointer will move to the number 100. This means that there are 100 puffs of medicine left (see **Figure A4-2c**).
- The **Dose indicator** number will continue to change after every 20 puffs.
- When the number in the **Dose indicator** window changes to 20 and the color behind the number changes to red, this means that there are only 20 puffs left in your inhaler. See **Figure A4-2d**.

Figure A4-2



Figure A4-2a
120 puffs



Figure A4-2b
110 puffs



Figure A4-2c
100 puffs



Figure A4-2d

Preparing the Inhaler for Use:

The inhaler comes in a foil pouch that contains a drying packet (desiccant).

- Take the inhaler out of the foil pouch.
- Throw away the pouch and the drying packet. Do not eat or inhale the contents of the drying packet.
- Remove the Cap from the Mouthpiece as shown in **Figure A4-3**.

Figure A4-3

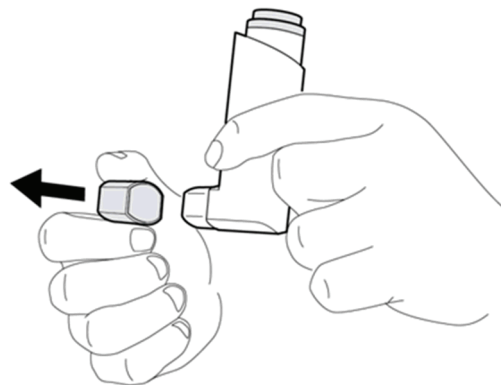

Prime the inhaler before you use it for the first time.

Priming the Inhaler:

- Check inside the **Mouthpiece** for objects before use.
- Hold the **Actuator** with the **Mouthpiece** pointing away from you and others as shown in **Figure A4-4a**.
- Shake the inhaler well before each puff.
- Push down fully on the center (not ‘off center’) of the **Dose indicator** on top of the **Canister** (see **Figure 1**) until the **Canister** stops moving in the **Actuator** to release a puff from the **Mouthpiece** as shown in **Figure A4-4b**. Note: It is normal to hear a soft click from the dose indicator as it counts down during use.
- Repeat this priming step 3 more times for a total of 4 times, shaking the inhaler each time before you press it.
- After completing the 4 priming puffs, your inhaler is now primed ready to use for the first time.

You must re-prime your inhaler again if you have not used it in more than 7 days. Take the cap off the mouthpiece and shake and spray the inhaler 2 times into the air away from your face.

Figure A4-4

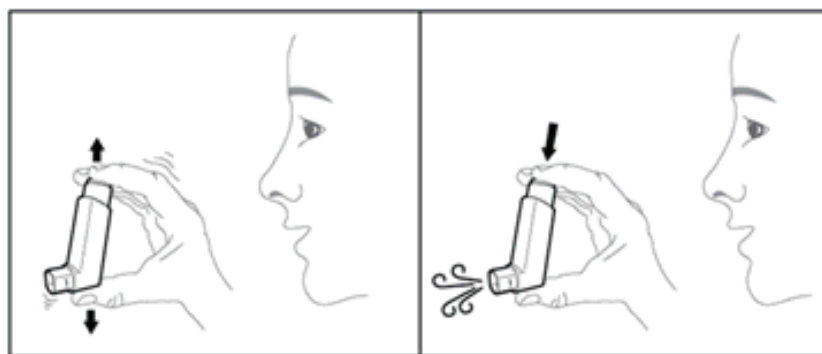

Figure A4-4a

Figure A4-4b

Using the Inhaler:

Your dose of medicine comes from **2 puffs** from the inhaler.

Refer to **Figure A4-5** for Step 1 through Step 8.

- **Step 1:** Remove the **Cap** from the **Mouthpiece**.
- **Step 2:** Shake the inhaler well before each puff.

- **Step 3:** While holding the inhaler with the **Mouthpiece** pointing towards you breathe out through your mouth to empty as much air from your lungs as possible.
- **Step 4:** Close your lips around the **Mouthpiece** and tilt your head back slightly to make sure your tongue is away from the **Mouthpiece**.
- **Step 5:** Take a deep breath in (inhale) slowly through your mouth while pressing down firmly on the center (not ‘off center’) of the **Dose indicator** until the **Canister** stops moving in the **Actuator** and a puff has been released. Then, stop pressing the **Dose indicator**.
- **Step 6:** When you have finished breathing in, remove the **Mouthpiece** from your mouth and hold your breath for 10 seconds or as long as comfortable.
- **Step 7:** Then, breathe out normally.

Take your second puff of medicine by repeating Step 2 through Step 7.

- **Step 8:** Replace the **Cap** back on the **Mouthpiece**.

Figure A4-5

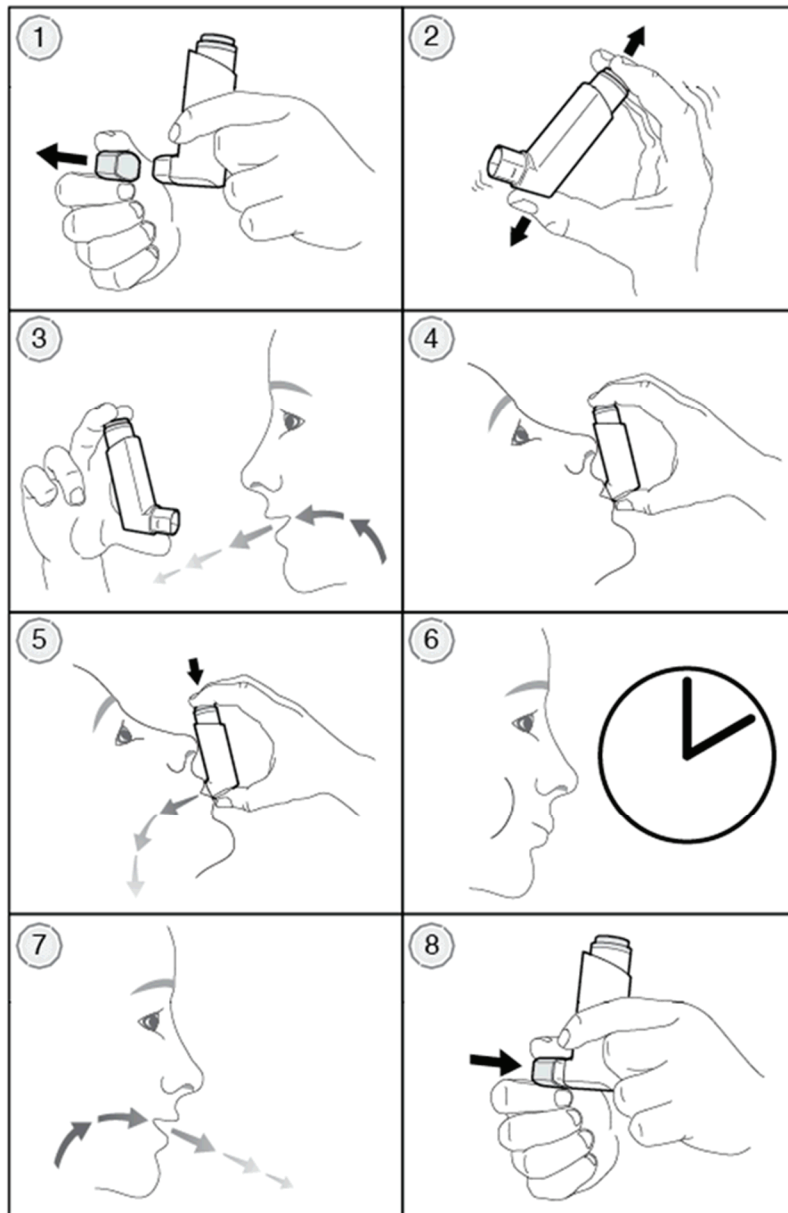

How to clean the inhaler:

It is very important to keep your inhaler clean so medicine will not build-up and block the spray through the **Mouthpiece**. See **Figure A4-6**.

Figure A4-6

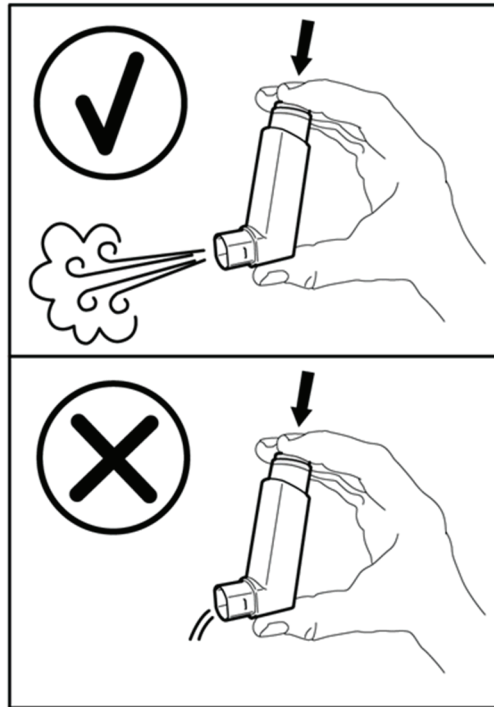

The **Canister** should be gently pulled from the top of the **Actuator** once a week and the **Actuator** cleaned. **Do not clean the Canister or let it get wet.**

- **Step 1:** Pull the **Canister** out of the **Actuator** as shown in **Figure A4-7**.

Figure A4-7

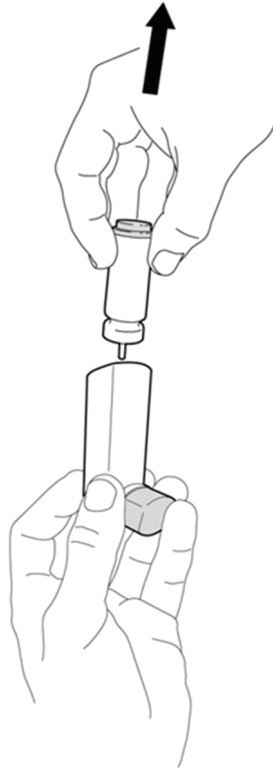

- **Step 2:** Set the **Canister** aside where it will not get wet.
- **Step 3:** Take the **Cap** off the **Mouthpiece**.
- **Step 4:** Rinse the **Actuator** through the top with warm running water for 30 seconds. Then rinse the actuator again through the **Mouthpiece** (see **Figure A4-8**).

Figure A4-8

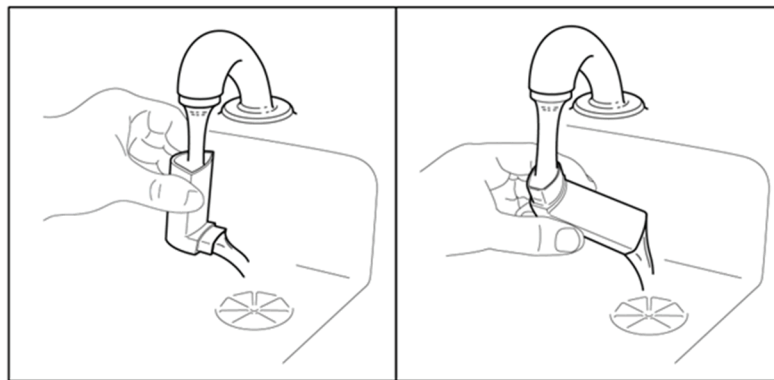

- **Step 5:** Shake all of the water droplets out of the **Actuator**.
- **Step 6:** Look in the **Actuator** and the **Mouthpiece** to make sure it is clean and clear.

Repeat **Step 4** through **Step 6**, until the **Actuator** and the **Mouthpiece** are clean and clear.

- **Step 7:** Let the **Actuator** dry completely, such as overnight as shown in **Figure A4-9**. **Do Not** put the **Canister** back into the **Actuator** if it is still wet.

Figure A4-9

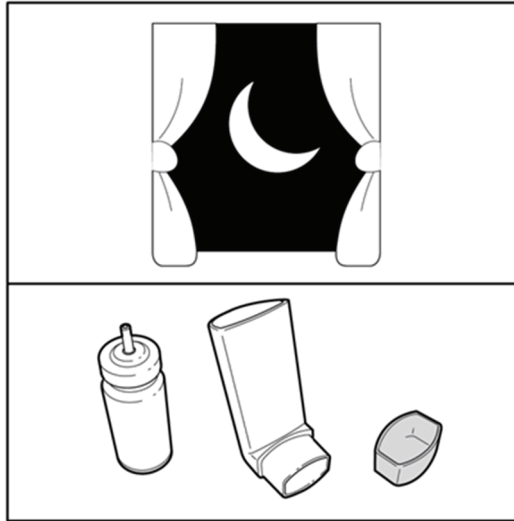

Reassembly of the Inhaler and Instructions for Use after Cleaning:

- After the **Actuator** is completely dry, gently press the **Canister** down in the **Actuator** as shown in **Figure A4-10**. It is not necessary to press down on the **Canister** hard enough to cause a puff to be released.

Figure A4-10

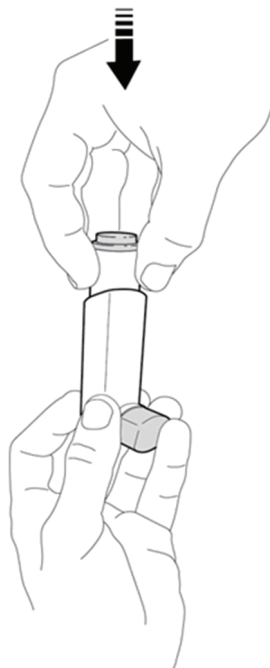

- Re-prime your inhaler 2 times after each cleaning.
- Hold the **Actuator** with the **Mouthpiece** pointing away from you and others as shown in **Figure A4-4**.
- Shake the inhaler well before each puff.
- Push down fully on the center (not ‘off center’) of the **Dose indicator** on top of the **Canister** until the **Canister** stops moving in the **Actuator** to release a puff from the **Mouthpiece**.
- Repeat this re-priming step 1 more time for a total of 2 times.
- After re-priming your inhaler 2 times, your inhaler is now ready to use.

Appendix 6 Instructions for Use of Spiriva® Respimat® (tiotropium) Inhalation Spray

Instructions for Use

SPIRIVA® RESPIMAT® (speh REE vah - RES peh mat)
(tiotropium bromide)
inhalation spray

For Oral Inhalation Only

Do not spray SPIRIVA RESPIMAT into your eyes

Read these Instructions for Use before you start using SPIRIVA RESPIMAT and each time you get a refill. There may be new information. This leaflet does not take the place of talking to your doctor about your medical condition or your treatment.

You will need to use this inhaler **ONCE A DAY**, at the same time each day. Each time you use it take **TWO PUFFS**.

Use **SPIRIVA RESPIMAT exactly as prescribed by your doctor**. Do not change your dose or how often you use SPIRIVA RESPIMAT without talking with your doctor. Children should use SPIRIVA RESPIMAT with the help of an adult, as instructed by their doctor.

Tell your doctor about all of the medicines you take. SPIRIVA RESPIMAT may affect the way some medicines work and some other medicines may affect the way SPIRIVA RESPIMAT works. Do not use other inhaled medicines with SPIRIVA RESPIMAT without talking to your doctor.

The SPIRIVA RESPIMAT inhaler has a slow moving mist that helps you inhale the medicine.

Do not turn the clear base before inserting the cartridge.

Your SPIRIVA RESPIMAT may have either an aqua or a blue cap, depending on the strength prescribed by your doctor. The steps shown below should be followed.

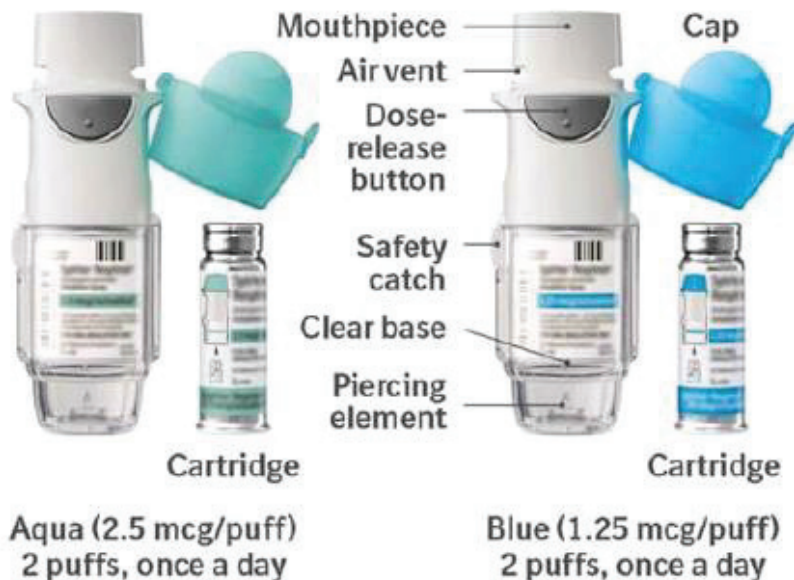

How to store your SPIRIVA RESPIMAT inhaler

- Store SPIRIVA RESPIMAT at room temperature 68°F to 77°F (20°C to 25°C).
- Do not freeze your SPIRIVA RESPIMAT cartridge and inhaler.
- If SPIRIVA RESPIMAT has not been used for more than 3 days, release 1 puff towards the ground.
- If SPIRIVA RESPIMAT has not been used for more than 21 days, repeat steps 4 to 6 under the “Prepare for first use” until a mist is visible. Then repeat steps 4 to 6 three more times.
- Keep your SPIRIVA RESPIMAT cartridge and inhaler out of the reach of children.

How to care for your SPIRIVA RESPIMAT inhaler

Clean the mouthpiece, including the metal part inside the mouthpiece, with a damp cloth or tissue only, at least once a week. Any minor discoloration in the mouthpiece does not affect your SPIRIVA RESPIMAT inhaler.

When to get a new SPIRIVA RESPIMAT inhaler

- Your inhaler contains 60 puffs (30 doses) if used as indicated (2 puffs once daily). If you have a sample, your inhaler contains 28 puffs (14 doses) if used as indicated (2 puffs once daily).



- The dose indicator shows approximately how much medicine is left.
- When the dose indicator enters the red area of the scale you need to get a refill; there is approximately medicine for 7 days left (if you have a sample, there is approximately medicine for 3 days left).
- When the dose indicator reaches the end of the red scale, your SPIRIVA RESPIMAT is empty and automatically locks. At this point, the clear base cannot be turned any further.
- Three months after insertion of cartridge, throw away the SPIRIVA RESPIMAT even if it has not been used, or when the inhaler is locked, or when it expires, whichever comes first.

Prepare for first use

1. Remove clear base

- Keep the cap closed.
- Press the safety catch while firmly pulling off the clear base with your other hand. Be careful not to touch the piercing element.
- Write the discard by date on the label (3 months from the date the cartridge is inserted).

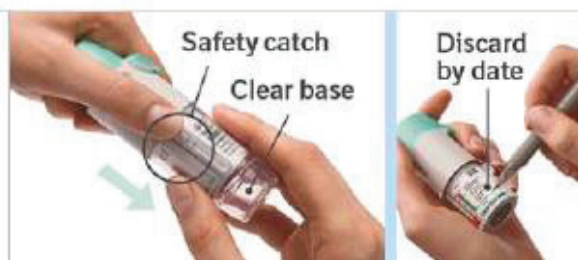

2. Insert cartridge

- Insert the narrow end of the cartridge into the inhaler.
- Place the inhaler on a firm surface and push down firmly until it clicks into place.



3. Replace clear base

- Put the clear base back into place until it clicks.
- Do not remove the clear base or the cartridge after it has been put together.



4. Turn

- Keep the cap closed.
- Turn the clear base in the direction of the arrows on the label until it clicks (half a turn).



5. Open

- Open the cap until it snaps fully open.



6. Press

- Point the inhaler toward the ground.
- Press the dose-release button.
- Close the cap.
- If you do not see a mist, repeat steps 4 to 6 until a mist is seen.
- **After a mist is seen, repeat steps 4 to 6 three more times.**
- After complete preparation of your inhaler, it will be ready to deliver the number of puffs on the label.

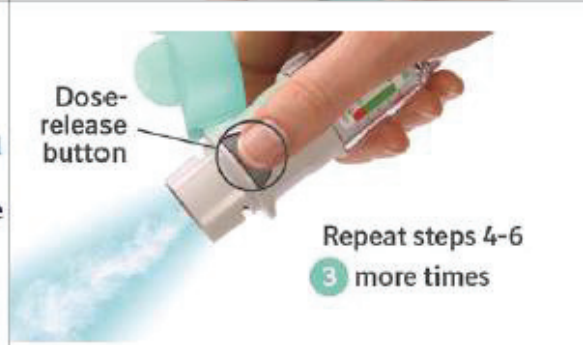

Daily use(TOP)

Turn

- Keep the cap closed.
- **Turn** the clear base in the direction of the arrows on the label until it clicks (half a turn).



Open

- **Open** the cap until it snaps fully open.



Press

- Breathe out slowly and fully.
- Close your lips around the mouthpiece without covering the air vents.
- Point the inhaler to the back of your throat.
- While taking a slow, deep breath through your mouth, **Press** the dose-release button and continue to breathe in.
- Hold your breath for 10 seconds or for as long as comfortable.
- Repeat **Turn, Open, Press (TOP)** for a total of 2 puffs.
- Close the cap until you use your inhaler again.



Answers to Common Questions

It is difficult to insert the cartridge deep enough:

Did you accidentally turn the clear base before inserting the cartridge? Open the cap, press the dose-release button, then insert the cartridge.

Did you insert the cartridge with the wide end first? Insert the cartridge with the narrow end first.

I cannot press the dose-release button:

Did you turn the clear base? If not, turn the clear base in a continuous movement until it clicks (half a turn).

Is the dose indicator on the SPIRIVA RESPIMAT pointing to zero? The SPIRIVA RESPIMAT inhaler is locked after 60 puffs (30 doses). If you have a sample, the SPIRIVA RESPIMAT inhaler is locked after 28 puffs (14 doses). Prepare and use your new SPIRIVA RESPIMAT inhaler.

I cannot turn the clear base:

Did you turn the clear base already? If the clear base has already been turned, follow steps “Open” and “Press” under “Daily use” to get your medicine.

Is the dose indicator on the SPIRIVA RESPIMAT pointing to zero? The SPIRIVA RESPIMAT inhaler is locked after 60 puffs (30 doses). If you have a sample, the SPIRIVA RESPIMAT inhaler is locked after 28 puffs (14 doses). Prepare and use your new SPIRIVA RESPIMAT inhaler.

The dose indicator on the SPIRIVA RESPIMAT reaches zero too soon:

Did you use SPIRIVA RESPIMAT as indicated (2 puffs once daily)? SPIRIVA RESPIMAT will deliver 60 puffs and last 30 days if used at 2 puffs once daily. If you have a sample, SPIRIVA RESPIMAT will deliver 28 puffs and last 14 days if used at 2 puffs once daily.

Did you turn the clear base before you inserted the cartridge? The dose indicator counts each turn of the clear base regardless whether a cartridge has been inserted or not.

Did you spray in the air often to check whether the SPIRIVA RESPIMAT is working? Once you have prepared SPIRIVA RESPIMAT, no test-spraying is required if used daily.

Did you insert the cartridge into a used SPIRIVA RESPIMAT? Always insert a new cartridge into a NEW SPIRIVA RESPIMAT.

My SPIRIVA RESPIMAT sprays automatically:

Was the cap open when you turned the clear base? Close the cap, then turn the clear base.

Did you press the dose-release button when turning the clear base? Close the cap, so the dose-release button is covered, then turn the clear base.

Did you stop when turning the clear base before it clicked? Turn the clear base in a continuous movement until it clicks (half a turn).

My SPIRIVA RESPIMAT doesn't spray:

Did you insert a cartridge? If not, insert a cartridge.

Did you repeat Turn, Open, Press (TOP) less than three times after inserting the cartridge? Repeat Turn, Open, Press (TOP) three times after inserting the cartridge as shown in steps 4 to 6 under “Prepare for first use”.

Is the dose indicator on the SPIRIVA RESPIMAT pointing to 0? You have used up all your medicine and the inhaler is locked.

For more information about SPIRIVA RESPIMAT or a video demonstration on how to use SPIRIVA RESPIMAT, go to www.spiriva.com or scan the code below. You may also call 1-800-542-6257 or (TTY) 1-800-459-9906 for further information about SPIRIVA RESPIMAT.

This Instructions for Use has been approved by the U.S. Food and Drug Administration.

Distributed by: Boehringer Ingelheim Pharmaceuticals, Inc., Ridgefield, CT 06877 USA

SPIRIVA® and RESPIMAT® are registered trademarks and are used under license from Boehringer Ingelheim International GmbH

Copyright © 2017 Boehringer Ingelheim International GmbH
ALL RIGHTS RESERVED

Revised: February 2017

Appendix 7 Instructions for Use of Ventolin[®] HFA (albuterol) Inhaler

Instructions for Use

For Oral Inhalation Only

Your VENTOLIN HFA inhaler

- The metal canister holds the medicine. See **Figure A**.

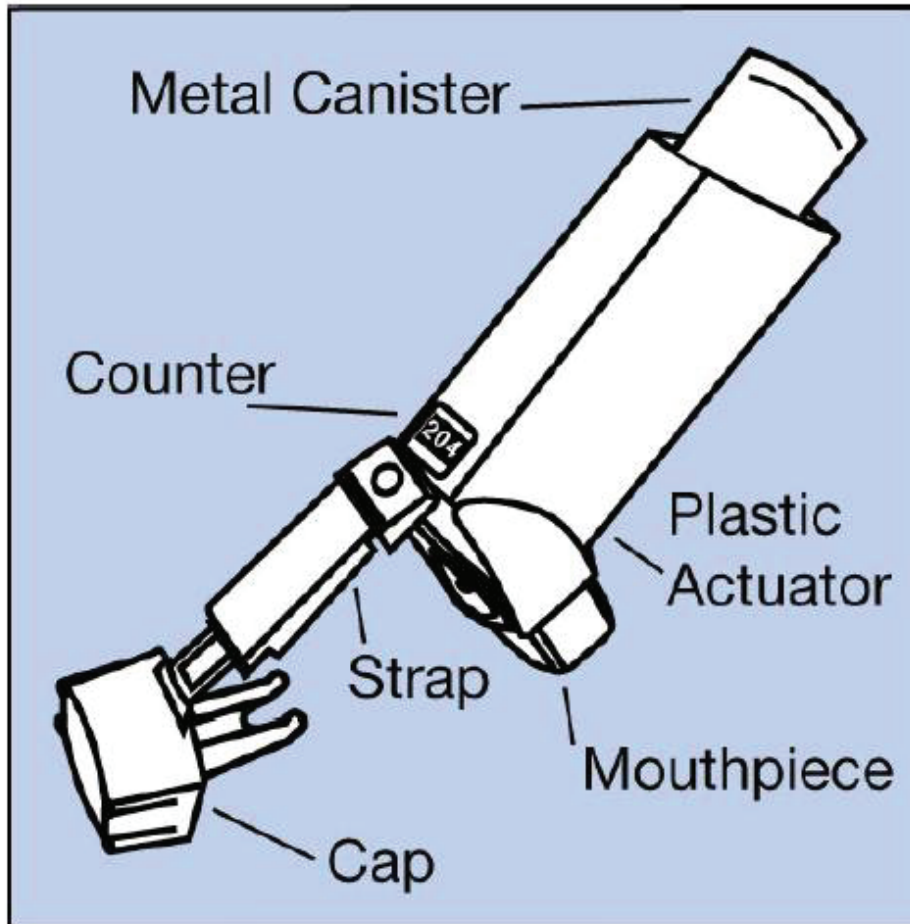

Figure A

- The canister has a counter to show how many sprays of medicine you have left. The number shows through a window in the back of the actuator. See **Figure B**.

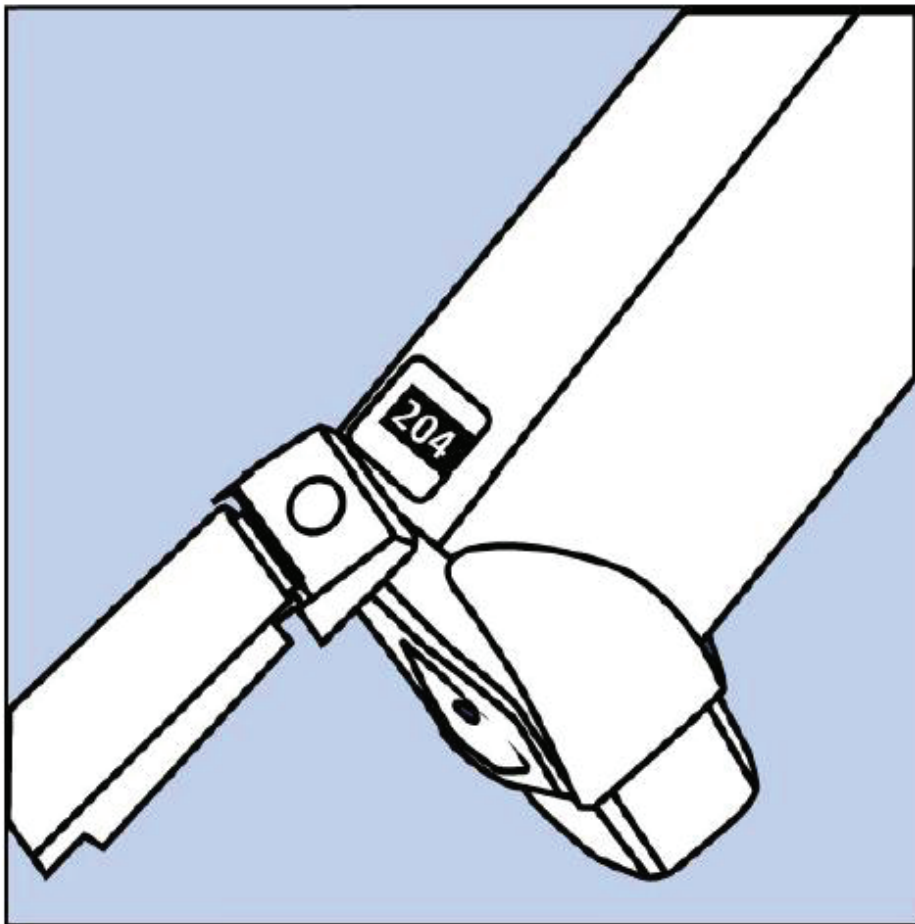

Figure B

- The counter starts at either **204** or **064**, depending on which size inhaler you have. The number will count down by 1 each time you spray the inhaler. The counter will stop counting at **000**.
- **Do not try to change the numbers or take the counter off the metal canister.** The counter cannot be reset, and it is permanently attached to the canister.
- The blue plastic actuator sprays the medicine from the canister. The actuator has a protective cap that covers the mouthpiece. **See Figure A.** Keep the protective cap on the mouthpiece when the canister is not in use. The strap keeps the cap attached to the actuator.
- **Do not** use the actuator with a canister of medicine from any other inhaler.
- **Do not** use a VENTOLIN HFA canister with an actuator from any other inhaler.

Before using your VENTOLIN HFA inhaler

- Take VENTOLIN HFA out of the foil pouch just before you use it for the first time. Safely throw away the pouch and the drying packet that comes inside the pouch.
- The inhaler should be at room temperature before you use it.
- If your child needs to use VENTOLIN HFA, watch your child closely to make sure your child uses the inhaler correctly. Your healthcare provider will show you how your child should use VENTOLIN HFA.

Priming your VENTOLIN HFA inhaler

- **Before you use VENTOLIN HFA for the first time, you must prime the inhaler so that you will get the right amount of medicine when you use it.**
- To prime the inhaler, take the cap off the mouthpiece and shake the inhaler well. Then spray the inhaler 1 time into the air away from your face. **See Figure C. Avoid spraying in eyes.**

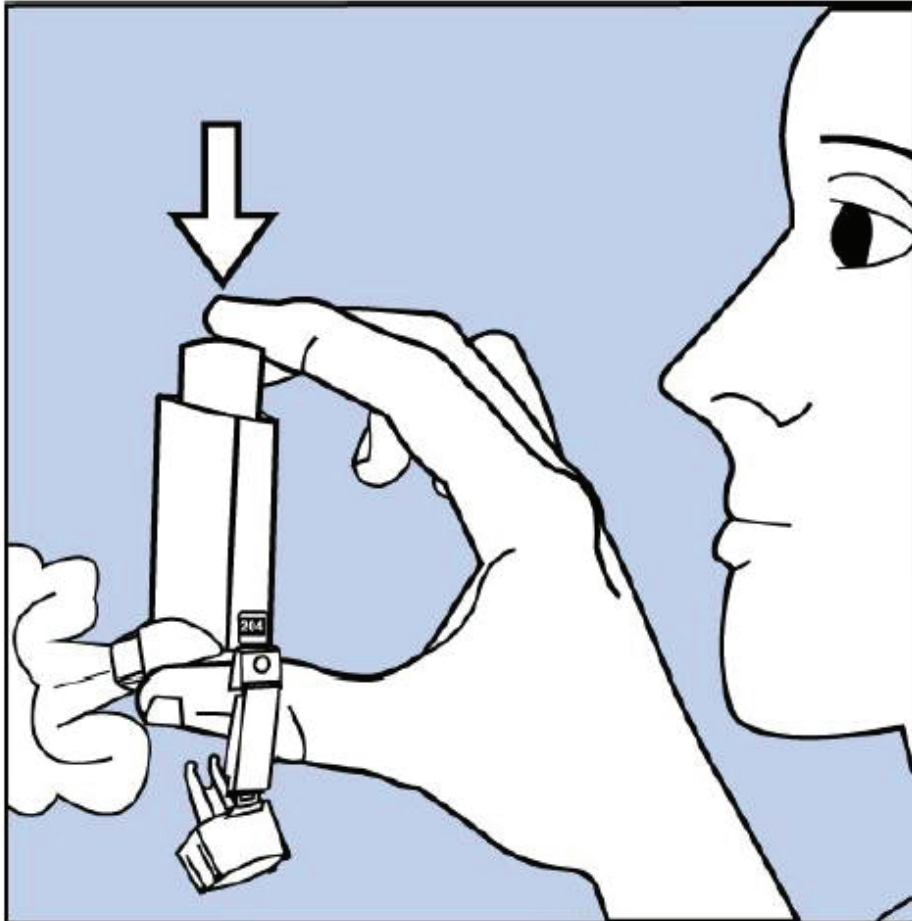

Figure C

- Shake and spray the inhaler like this 3 more times to finish priming it. The counter should now read **200** or **060**, depending on which size inhaler you have. **See Figure D.**

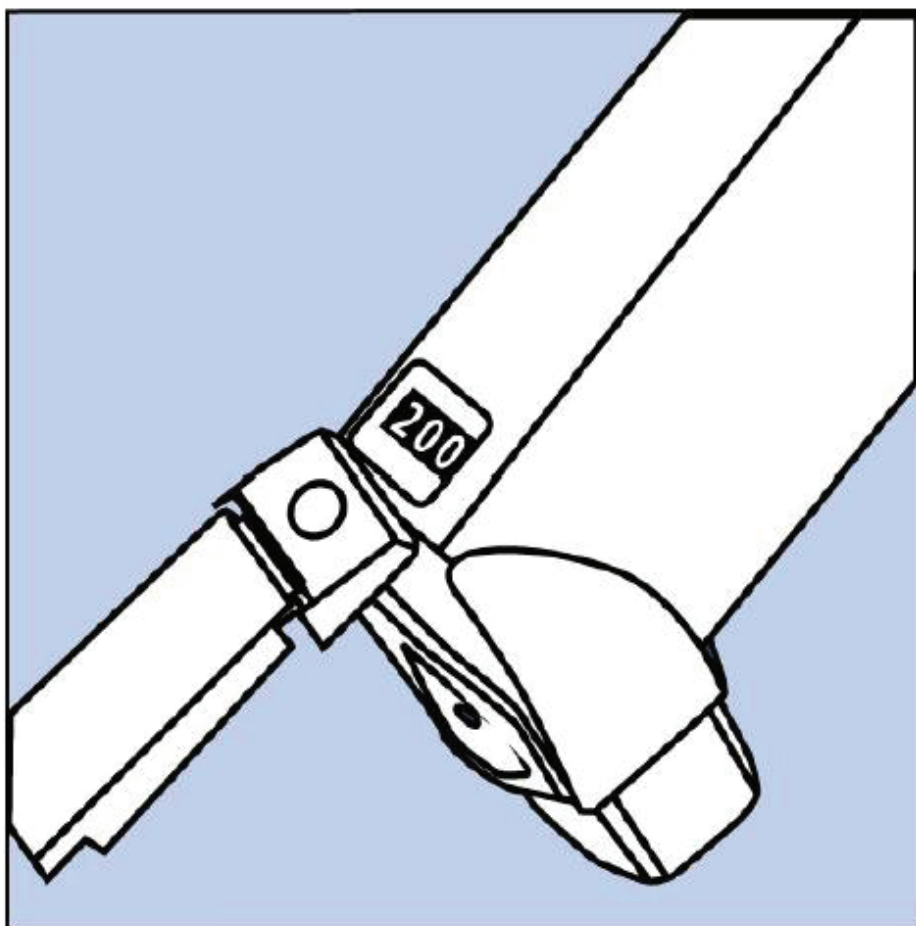

Figure D

- You must prime your inhaler again if you have not used it in more than 14 days or if you drop it. Take the cap off the mouthpiece and shake and spray the inhaler 4 times into the air away from your face.

How to use your VENTOLIN HFA inhaler

Follow these steps every time you use VENTOLIN HFA.

Step 1. Make sure the canister fits firmly in the actuator. The counter should show through the window in the actuator.

Shake the inhaler well before each spray.

Take the cap off the mouthpiece of the actuator. Look inside the mouthpiece for foreign objects, and take out any you see.

Step 2. Hold the inhaler with the mouthpiece down. See **Figure E**.

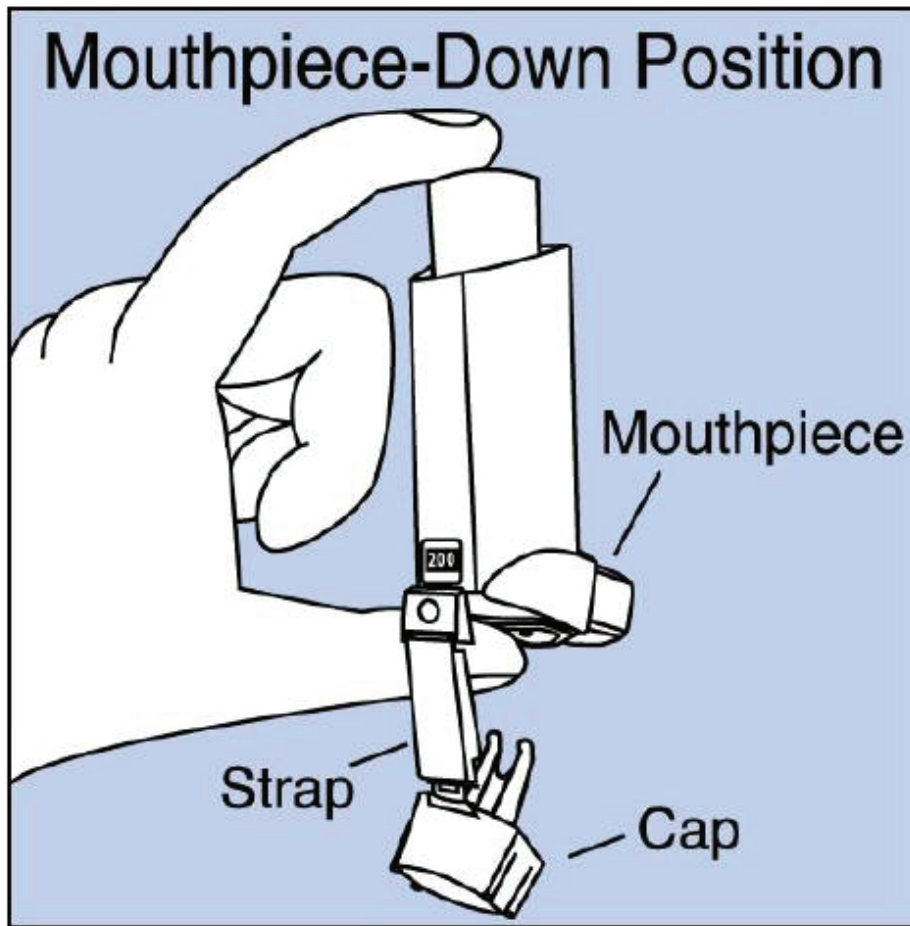

Figure E

Step 3. Breathe out through your mouth and push as much air from your lungs as you can. Put the mouthpiece in your mouth and close your lips around it. See Figure F.

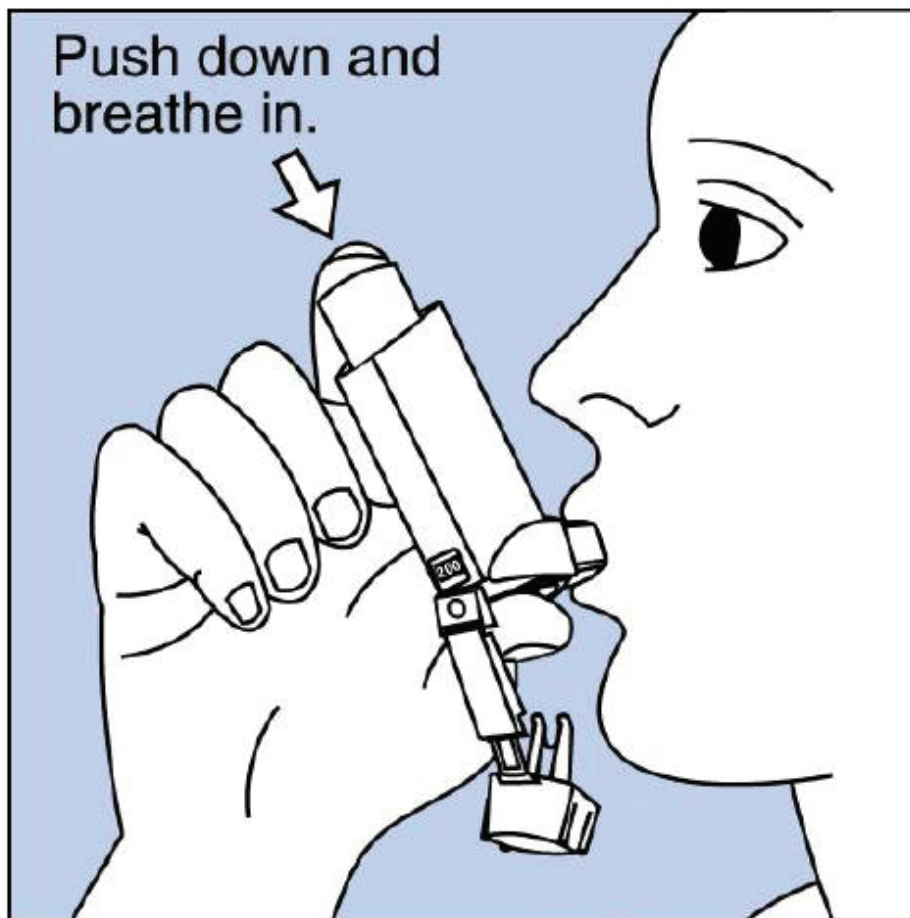

Figure F

Step 4. Push the top of the canister **all the way down** while you breathe in deeply and slowly through your mouth. **See Figure F.**

Step 5. After the spray comes out, take your finger off the canister. After you have breathed in all the way, take the inhaler out of your mouth and close your mouth.

Step 6. **Hold your breath for about 10 seconds**, or for as long as is comfortable. **Breathe out slowly as long as you can.**

If your healthcare provider has told you to use more sprays, wait 1 minute and shake the inhaler again. Repeat Steps 2 through Step 6.

Step 7. Put the cap back on the mouthpiece after every time you use the inhaler. Make sure it snaps firmly into place.

Cleaning your VENTOLIN HFA inhaler

Clean your inhaler at least 1 time each week. You may not see any medicine build-up on the inhaler, but it is important to keep it clean so medicine build-up will not block the spray. **See Figure G.**

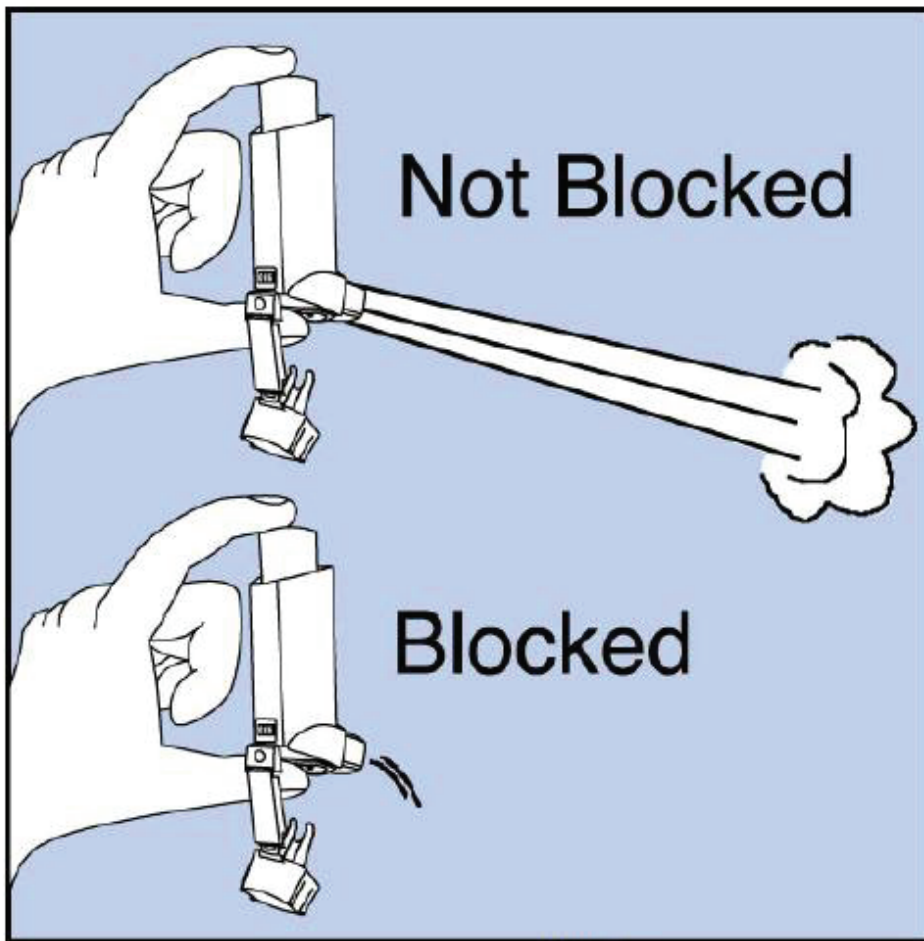

Figure G

Step 8. Take the canister out of the actuator, and take the cap off the mouthpiece. The strap on the cap will stay attached to the actuator.

Step 9. Hold the actuator under the faucet and run warm water through it for about 30 seconds. See **Figure H.**

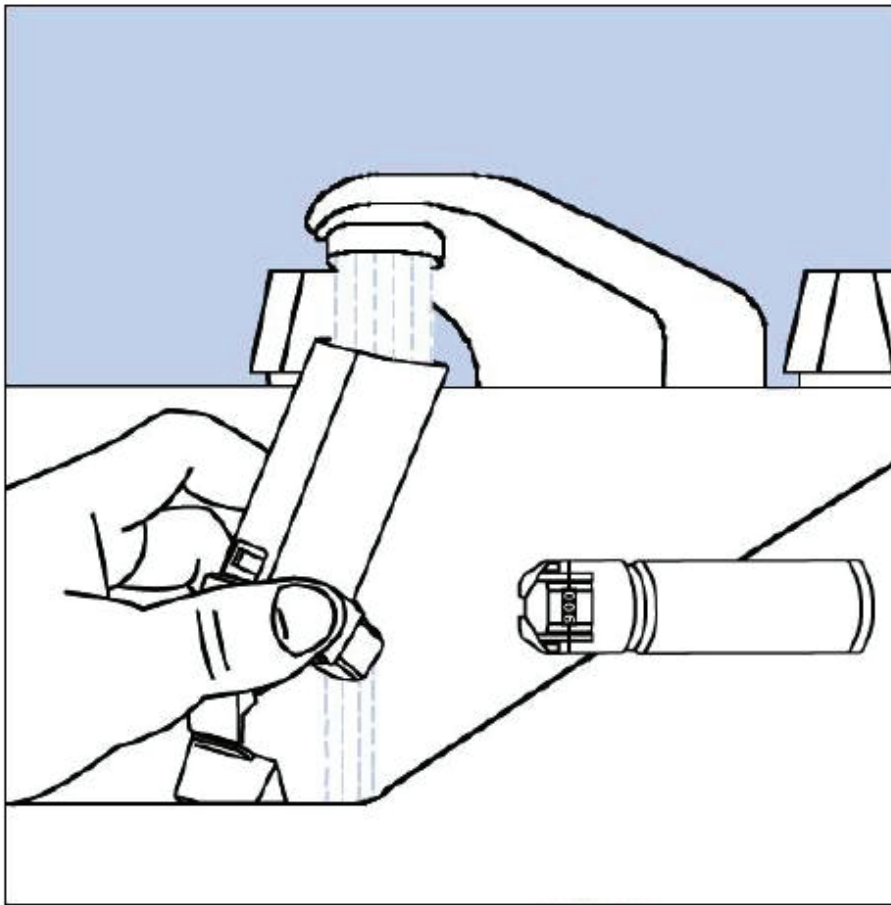

Figure H

Step 10. Turn the actuator upside down and run warm water through the mouthpiece for about 30 seconds. See Figure I.

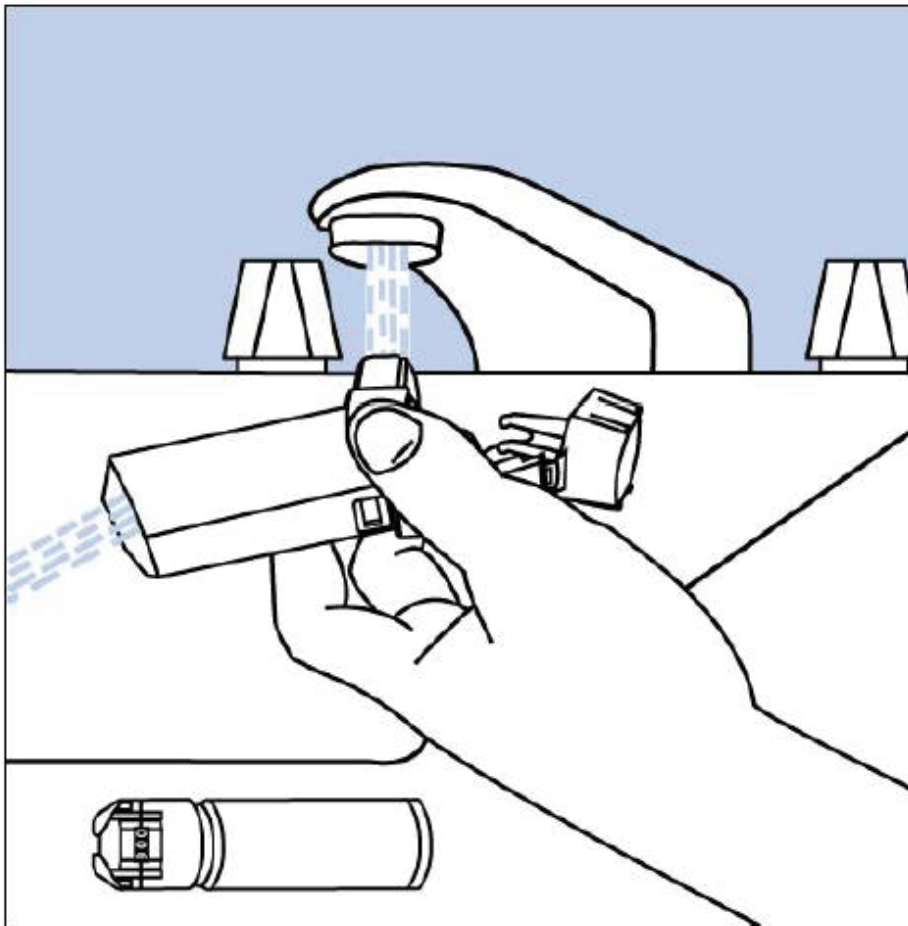

Figure I

Step 11. Shake off as much water from the actuator as you can. Look into the mouthpiece to make sure any medicine build-up has been completely washed away. If there is any build-up, repeat Steps 9 and 10

Step 12. Let the actuator air-dry overnight. See Figure J.

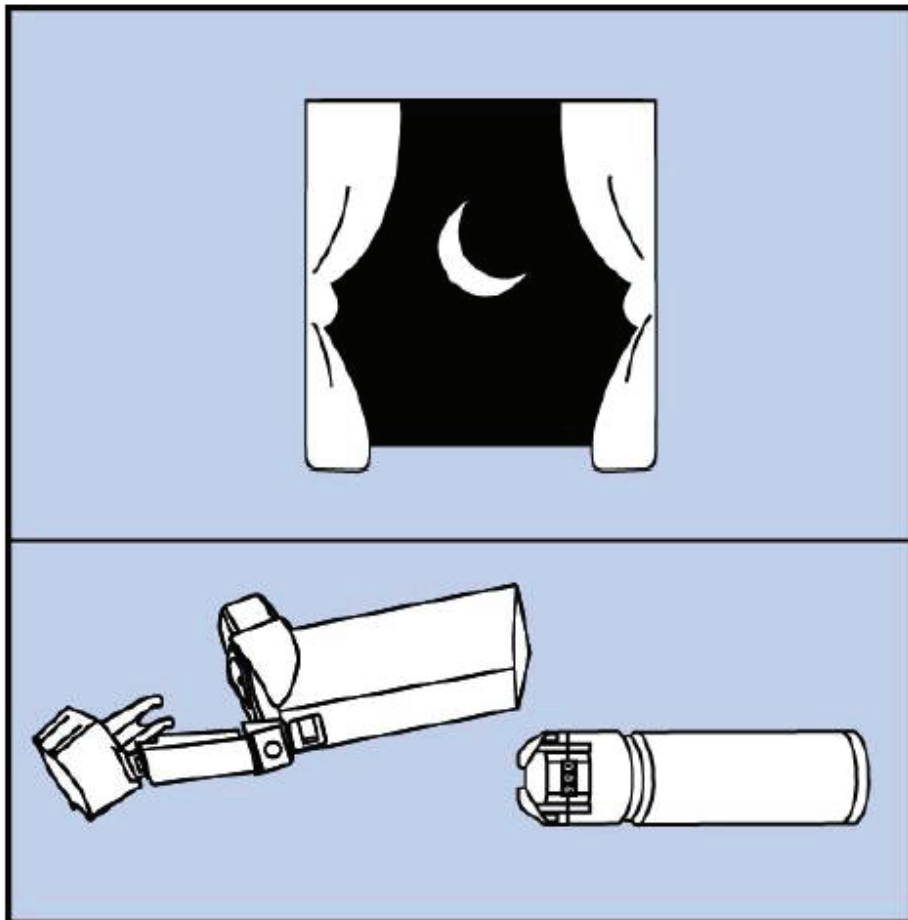

Figure J

Step 13. When the actuator is dry, put the protective cap on the mouthpiece and then put the canister in the actuator and make sure it fits firmly. Shake the inhaler well, remove the cap, and spray the inhaler once into the air away from your face. (The counter will count down by 1 number.) Put the cap back on the mouthpiece.

If you need to use your inhaler before the actuator is completely dry:

- Shake as much water off the actuator as you can.
- Put the cap on the mouthpiece and then put the canister in the actuator and make sure it fits firmly.
- Shake the inhaler well and spray it 1 time into the air away from your face.
- Take your VENTOLIN HFA dose as prescribed.
- Follow cleaning Steps 8 through 13 above.

Replacing your VENTOLIN HFA inhaler:

- **When the counter reads 020**, you should refill your prescription or ask your healthcare provider if you need another prescription for VENTOLIN HFA.
- **Throw the inhaler away** when the counter reads **000** or 12 months after you opened the foil pouch, whichever comes first. You should not keep using the inhaler when the counter reads **000** because you will not receive the right amount of medicine.

- **Do not use the inhaler** after the expiration date, which is on the packaging it comes in.

For correct use of your VENTOLIN HFA inhaler, remember:

- The canister should always fit firmly in the actuator.
- Breathe in deeply and slowly to make sure you get all the medicine.
- Hold your breath for about 10 seconds after breathing in the medicine. Then breathe out fully.
- Always keep the protective cap on the mouthpiece when your inhaler is not in use.
- Always store your inhaler with the mouthpiece pointing down.
- Clean your inhaler at least 1 time each week.

If you have questions about VENTOLIN HFA or how to use your inhaler, call GlaxoSmithKline (GSK) at 1-888-825-5249 or visit www.ventolin.com.

This Patient Information and Instructions for Use have been approved by the U.S. Food and Drug Administration.

VENTOLIN is a registered trademark of the GSK group of companies.

GlaxoSmithKline

Research Triangle Park, NC 27709

©2014, the GSK group of companies. All rights reserved.

December 2014

Appendix 8 Instructions for Use of Atrovent® HFA (ipratropium) Inhaler

INSTRUCTIONS FOR USE

Atrovent® HFA (ipratropium bromide HFA) Inhalation Aerosol

Read the Instructions for Use before using your ATROVENT HFA and each time you get a refill. There may be new information. This leaflet does not take the place of talking with your healthcare provider about your medical condition or your treatment.

Use ATROVENT HFA exactly as your healthcare provider tells you to. Do not change your dose or how often you use ATROVENT HFA without talking with your healthcare provider.

Tell your doctor about all the medicines you take. ATROVENT HFA may affect the way some other medicines work and some other medicines may affect the way ATROVENT HFA works.

Important information about using ATROVENT HFA

- You do not have to shake ATROVENT HFA before using it.
- **ATROVENT HFA** should be "primed" 2 times before you use the first dose of a new ATROVENT HFA inhaler or when the inhaler has not been used for more than 3 days.
 - To prime, push the canister against the mouthpiece (See Figure 1), allowing the medicine to spray into the air.
 - **Do not spray the medicine into your eyes while priming ATROVENT HFA.**

Inhaler Description

ATROVENT HFA Inhalation Aerosol (Figure 1) consists of a metal canister containing the medicine and a mouthpiece that releases the medicine from the canister. The mouthpiece includes a clear colorless sleeve, a white plastic portion and a green protective dust cap.

The inhaler comes with a dose indicator you can see through a small window on the plastic mouthpiece (See Figure 1). A new inhaler first shows “200” in the dose indicator window. The dose indicator will show the approximate number of actuations (sprays) of medicine remaining in the inhaler. As you use the inhaler, the dose indicator will typically rotate during every 5 to 7 actuations (sprays) towards the next decreasing number (See Figure 2).

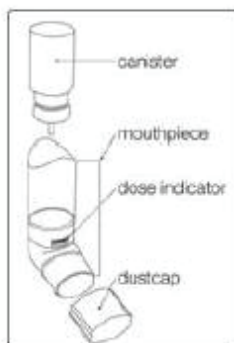

Figure 1



Figure 2

Instructions for Use:

- 1. Insert the metal canister into the clear end of the mouthpiece (See Figure 1).** Make sure the canister is fully and firmly inserted into the mouthpiece.
 - **The ATROVENT HFA canister is to be used only with the ATROVENT HFA mouthpiece.**
 - **Do not use the ATROVENT HFA mouthpiece with other inhaled medicines.**
- 2. Remove the green protective dust cap.** If the cap is not on the mouthpiece, make sure there is nothing in the mouthpiece before use. For best results, the canister should be at room temperature before use.
- 3. Breathe out (exhale) deeply through your mouth.** Hold the inhaler upright (See Figure 3), between your thumb and first 2 fingers. Put the mouthpiece in your mouth and close your lips.
 - **Keep your eyes closed so that no medicine will be sprayed into your eyes.** If sprayed into the eyes, ATROVENT HFA can cause blurry vision and other vision abnormalities, eye pain or discomfort, dilated pupils, or narrow-angle glaucoma or worsening of this condition. If any

combination of these symptoms develops, you should consult your physician immediately.



Figure 3

4. **Breathe in (inhale) slowly through your mouth and at the same time spray the ATROVENT HFA into your mouth.**

- To spray ATROVENT HFA firmly press the canister against the mouthpiece 1 time (See Figure 4). Keep breathing in deeply.



Figure 4

5. **Hold your breath for ten seconds and then take the mouthpiece out of your mouth and breathe out slowly (See Figure 5).**



Figure 5

6. **Wait at least 15 seconds and repeat steps 3 to 5 again.**

7. **Replace the green protective dust cap after use.**

8. **Keep the mouthpiece clean.** At least once a week, wash the mouthpiece, shake it to remove excess water and let it air dry all the way (see **Mouthpiece Cleaning Instructions**).

Mouthpiece Cleaning Instructions:

Step A. Remove and set aside the canister and dust cap from the mouthpiece (See Figure 1).

Step B. Wash the mouthpiece through the top and bottom with warm running water for at least 30 seconds (See Figure 6). Do not use anything other than water to wash the mouthpiece.



Figure 6

Step C. Dry the mouthpiece by shaking off the excess water and allow it to air dry all the way.

Step D. When the mouthpiece is dry, replace the canister. Make sure the canister is fully and firmly inserted into the mouthpiece.

Step E. Replace the green protective dust cap.

If little or no medicine comes out of the mouthpiece, wash the mouthpiece as described in Steps A to E under the "**Mouthpiece Cleaning Instructions**".

9. When to get a new ATROVENT HFA inhaler.

There are approximately 40 actuations (sprays) left when the dose indicator displays "40," where the background changes from green to red (See Figure 7a). This is when you need to refill your prescription or ask your doctor if you need another prescription for ATROVENT HFA inhalation aerosol.

The background color will be all red when the indicator approaches 20. The indicator will stop moving at "0". Discard the inhaler once the dose indicator displays "0" (See Figure 7b). Even though the canister may not be empty, you cannot be sure of the amount of medicine in each actuation (spray) once the dose indicator displays "0".

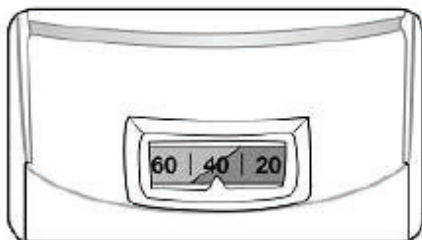

Figure 7a

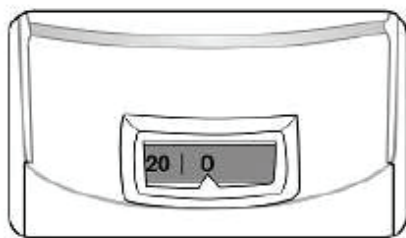

Figure 7b

This product does not contain any chlorofluorocarbon (CFC) propellants.

The contents of ATROVENT HFA are under pressure. Do not puncture the canister. Do not use or store near heat or open flame. Exposure to temperatures above 120°F may cause bursting. Never throw the container into a fire or incinerator.

Keep ATROVENT HFA and all medicines out of the reach of children.

Address medical inquiries to: <http://us.boehringer-ingelheim.com>, (800) 542-6257 or (800) 459-9906 TTY.

Store ATROVENT HFA at Room Temperature [77°F (25°C)]. Short-term exposure to higher or lower temperatures [from 59°F (15°C) to 86°F (30°C)] is acceptable.

Distributed by:
Boehringer Ingelheim Pharmaceuticals, Inc.
Ridgefield, CT 06877 USA

Licensed from:
Boehringer Ingelheim International GmbH

Copyright 2012 Boehringer Ingelheim International GmbH
ALL RIGHTS RESERVED

IT1902III22012
10003001/09

Revised: August 2012

Atrovent HFA (ipratropium bromide HFA)
NDC 0597-0087-17
200 metered actuations

Appendix 9 Asthma Control Questionnaire (ACQ)

The ACQ-5, ACQ-6, and ACQ-7 comprise questions 1 through 5, questions 1 through 6, and all 7 questions, respectively.

(The sample provided here is for illustrative purposes only)

ASTHMA CONTROL QUESTIONNAIRE (ACQ)

© 1997
QOL TECHNOLOGIES LTD.



For further information:

Elizabeth Juniper, MCSP, MSc
Professor
20 Marcuse Fields
Bosham, West Sussex
PO18 8NA, England
Telephone: +44 1243 572124
Fax: +44 1243 573680
E-mail: juniper@qoltech.co.uk
Web: <http://www.qoltech.co.uk>

© The Asthma Control Questionnaire (ACQ) is copyrighted and all rights are reserved. No part of this questionnaire may be sold, modified or reproduced in any form without the express permission of Elizabeth Juniper on behalf of QOL Technologies Limited

DECEMBER 2002

Revised September 2010
ACQ-SA North American English Version

ASTHMA CONTROL QUESTIONNAIRE©

PATIENT ID: _____

DATE: _____

Page 1 of 2

Please answer questions 1 - 6.

Circle the number of the response that best describes how you have been during the past week.

- | | |
|--|-------------------------------------|
| 1. On average, during the past week, how often were you woken by your asthma during the night? | 0 Never |
| | 1 Hardly ever |
| | 2 A few times |
| | 3 Several times |
| | 4 Many times |
| | 5 A great many times |
| | 6 Unable to sleep because of asthma |
|
 | |
| 2. On average, during the past week, how bad were your asthma symptoms when you woke up in the morning? | 0 No symptoms |
| | 1 Very mild symptoms |
| | 2 Mild symptoms |
| | 3 Moderate symptoms |
| | 4 Quite severe symptoms |
| | 5 Severe symptoms |
| | 6 Very severe symptoms |
|
 | |
| 3. In general, during the past week, how limited were you in your activities because of your asthma? | 0 Not limited at all |
| | 1 Very slightly limited |
| | 2 Slightly limited |
| | 3 Moderately limited |
| | 4 Very limited |
| | 5 Extremely limited |
| | 6 Totally limited |
|
 | |
| 4. In general, during the past week, how much shortness of breath did you experience because of your asthma? | 0 None |
| | 1 A very little |
| | 2 A little |
| | 3 A moderate amount |
| | 4 Quite a lot |
| | 5 A great deal |
| | 6 A very great deal |

Revised September 2010
ACQ-SA North American English Version

ASTHMA CONTROL QUESTIONNAIRE©

PATIENT ID: _____

DATE: _____

Page 2 of 2

5. In general, during the past week, how much of the time did you wheeze?
- | | |
|---|-------------------------------|
| 0 | Not at all |
| 1 | Hardly any of the time |
| 2 | A little of the time |
| 3 | A moderate amount of the time |
| 4 | A lot of the time |
| 5 | Most of the time |
| 6 | All the time |
6. On average, during the past week, how many puffs/inhalations of short-acting bronchodilator (eg. Ventolin/Bricanyl) have you used each day?
(If you are not sure how to answer this question, please ask for help)
- | | |
|---|--|
| 0 | None |
| 1 | 1 - 2 puffs/inhalations most days |
| 2 | 3 - 4 puffs/inhalations most days |
| 3 | 5 - 8 puffs/inhalations most days |
| 4 | 9 - 12 puffs/inhalations most days |
| 5 | 13 - 16 puffs/inhalations most days |
| 6 | More than 16 puffs/inhalations most days |

To be completed by a member of the clinic staff

7. FEV₁pre-bronchodilator: 0 > 95% predicted
1 95 - 90%
FEV₁predicted: 2 89 - 80%
3 79 - 70%
FEV₁%predicted: 4 69 - 60%
(Record actual values on the dotted 5 59 - 50%
lines and score the FEV₁ % predicted 6 < 50% predicted
in the next column)

Appendix 10 Asthma Quality of Life Questionnaire for 12 Years and Older (AQLQ +12)

(The sample provided here is for illustrative purposes only)

ASTHMA QUALITY OF LIFE QUESTIONNAIRE WITH STANDARDISED ACTIVITIES (AQLQ(S))

SELF-ADMINISTERED
(≥12 years)

© 1998
QOL TECHNOLOGIES LTD.



For further information:

Elizabeth Juniper, MCSP, MSc
Professor
20 Marcuse Fields
Bosham, West Sussex
PO18 8NA, England
Telephone: +44 1243 572124
Fax: +44 1243 573680
E-mail: juniper@qoltech.co.uk
Web: <http://www.qoltech.co.uk>

© The Asthma Quality of Life Questionnaire with Standardised Activities (AQLQ(S)) is copyrighted and all rights are reserved. No part of this questionnaire may be sold, modified or reproduced in any form without the express permission of Elizabeth Juniper on behalf of QOL Technologies Limited

APRIL 2008

Modified September 2010
AQLQ(S) ≥12 years SA North American English Version

ASTHMA QUALITY OF LIFE QUESTIONNAIRE (S)

PATIENT ID: _____

SELF-ADMINISTERED

DATE: _____

Page 1 of 5

Please complete all questions by circling the number that best describes how you have been during the last 2 weeks as a result of your asthma.

HOW LIMITED HAVE YOU BEEN DURING THE LAST 2 WEEKS IN THESE ACTIVITIES AS A RESULT OF YOUR ASTHMA?

	Totally Limited	Extremely Limited	Very Limited	Moderate Limitation	Some Limitation	A Little Limitation	Not at all Limited
1. STRENUOUS ACTIVITIES (such as hurrying, exercising, running up stairs, sports)	1	2	3	4	5	6	7
2. MODERATE ACTIVITIES (such as walking, housework, gardening, shopping, climbing stairs)	1	2	3	4	5	6	7
3. SOCIAL ACTIVITIES (such as talking, playing with pets/children, visiting friends/relatives)	1	2	3	4	5	6	7
4. WORK/SCHOOL-RELATED ACTIVITIES* (tasks you have to do at work/in school)	1	2	3	4	5	6	7
5. SLEEPING	1	2	3	4	5	6	7

*If you are not employed or self-employed, these should be tasks you have to do most days.

HOW MUCH DISCOMFORT OR DISTRESS HAVE YOU FELT DURING THE LAST 2 WEEKS?

	A Very Great Deal	A Great Deal	A Good Deal	Moderate Amount	Some	Very Little	None
6. How much discomfort or distress have you felt over the last 2 weeks as a result of CHEST TIGHTNESS?	1	2	3	4	5	6	7

Modified September 2010
 AQLQ(S) ≥12 years SA North American English Version

ASTHMA QUALITY OF LIFE QUESTIONNAIRE (S)

PATIENT ID: _____

SELF-ADMINISTERED

DATE: _____

Page 2 of 5

IN GENERAL, HOW MUCH OF THE TIME DURING THE LAST 2 WEEKS DID YOU:

	All of the Time	Most of the Time	A Good Bit of the Time	Some of the Time	A Little of the Time	Hardly Any of the Time	None of the Time
7. Feel CONCERNED ABOUT HAVING ASTHMA?	1	2	3	4	5	6	7
8. Feel SHORT OF BREATH as a result of your asthma?	1	2	3	4	5	6	7
9. Experience asthma symptoms as a RESULT OF BEING EXPOSED TO CIGARETTE SMOKE?	1	2	3	4	5	6	7
10. Experience a WHEEZE in your chest?	1	2	3	4	5	6	7
11. Feel you had to AVOID A SITUATION OR ENVIRONMENT BECAUSE OF CIGARETTE SMOKE?	1	2	3	4	5	6	7

HOW MUCH DISCOMFORT OR DISTRESS HAVE YOU FELT DURING THE LAST 2 WEEKS?

	A Very Great Deal	A Great Deal	A Good Deal	Moderate Amount	Some	Very Little	None
12. How much discomfort or distress have you felt over the last 2 weeks as a result of COUGHING?	1	2	3	4	5	6	7

IN GENERAL, HOW MUCH OF THE TIME DURING THE LAST 2 WEEKS DID YOU:

	All of the Time	Most of the Time	A Good Bit of the Time	Some of the Time	A Little of the Time	Hardly Any of the Time	None of the Time
13. Feel FRUSTRATED as a result of your asthma?	1	2	3	4	5	6	7
14. Experience a feeling of CHEST HEAVINESS?	1	2	3	4	5	6	7

Modified September 2010
 AQLQ(S) ≥12 years SA North American English Version

ASTHMA QUALITY OF LIFE QUESTIONNAIRE (S)

PATIENT ID: _____

SELF-ADMINISTERED

DATE: _____

Page 3 of 5

IN GENERAL, HOW MUCH OF THE TIME DURING THE LAST 2 WEEKS DID YOU:

	All of the Time	Most of the Time	A Good Bit of the Time	Some of the Time	A Little of the Time	Hardly Any of the Time	None of the Time
15. Feel CONCERNED ABOUT THE NEED TO USE MEDICATION for your asthma?	1	2	3	4	5	6	7
16. Feel the need to CLEAR YOUR THROAT?	1	2	3	4	5	6	7
17. Experience asthma symptoms as a RESULT OF BEING EXPOSED TO DUST?	1	2	3	4	5	6	7
18. Experience DIFFICULTY BREATHING OUT as a result of your asthma?	1	2	3	4	5	6	7
19. Feel you had to AVOID A SITUATION OR ENVIRONMENT BECAUSE OF DUST?	1	2	3	4	5	6	7
20. WAKE UP IN THE MORNING WITH ASTHMA SYMPTOMS?	1	2	3	4	5	6	7
21. Feel AFRAID OF NOT HAVING YOUR ASTHMA MEDICATION AVAILABLE?	1	2	3	4	5	6	7
22. Feel bothered by HEAVY BREATHING?	1	2	3	4	5	6	7
23. Experience asthma symptoms as a RESULT OF THE WEATHER OR AIR POLLUTION OUTSIDE?	1	2	3	4	5	6	7
24. Were you WOKEN AT NIGHT by your asthma?	1	2	3	4	5	6	7
25. AVOID OR LIMIT GOING OUTSIDE BECAUSE OF THE WEATHER OR AIR POLLUTION?	1	2	3	4	5	6	7

Modified September 2010
 AQLQ(S) ≥12 years SA North American English Version

ASTHMA QUALITY OF LIFE QUESTIONNAIRE (S)

PATIENT ID: _____

SELF-ADMINISTERED

DATE: _____

Page 4 of 5

IN GENERAL, HOW MUCH OF THE TIME DURING THE LAST 2 WEEKS DID YOU:

	All of the Time	Most of the Time	A Good Bit of the Time	Some of the Time	A Little of the Time	Hardly Any of the Time	None of the Time
26. Experience asthma symptoms as a RESULT OF BEING EXPOSED TO STRONG SMELLS OR PERFUME?	1	2	3	4	5	6	7
27. Feel AFRAID OF GETTING OUT OF BREATH?	1	2	3	4	5	6	7
28. Feel you had to AVOID A SITUATION OR ENVIRONMENT BECAUSE OF STRONG SMELLS OR PERFUME?	1	2	3	4	5	6	7
29. Has your asthma INTERFERED WITH GETTING A GOOD NIGHT'S SLEEP?	1	2	3	4	5	6	7
30. Have a feeling of FIGHTING FOR AIR?	1	2	3	4	5	6	7

HOW LIMITED HAVE YOU BEEN DURING THE LAST 2 WEEKS?

	Severely Limited Most Not Done	Very Limited	Moderately Limited Several Not Done	Slightly Limited	Very Slightly Limited Very Few Not Done	Hardly Limited At All	Not Limited Have Done All Activities
31. Think of the OVERALL RANGE OF ACTIVITIES that you would have liked to have done during the last 2 weeks. How much has your range of activities been limited by your asthma?	1	2	3	4	5	6	7

Modified September 2010
 AQLQ(S) ≥12 years SA North American English Version

ASTHMA QUALITY OF LIFE QUESTIONNAIRE (S)

PATIENT ID: _____

SELF-ADMINISTERED

DATE: _____

Page 5 of 5

HOW LIMITED HAVE YOU BEEN DURING THE LAST 2 WEEKS?

	Totally Limited	Extremely Limited	Very Limited	Moderate Limitation	Some Limitation	A Little Limitation	Not at all Limited
32. Overall, among ALL THE ACTIVITIES that you have done during the last 2 weeks, how limited have you been by your asthma?	1	2	3	4	5	6	7

DOMAIN CODE:

Symptoms: 6, 8, 10, 12, 14, 16, 18, 20, 22, 24, 29, 30
Activity Limitation: 1, 2, 3, 4, 5, 11, 19, 25, 28, 31, 32
Emotional Function: 7, 13, 15, 21, 27
Environmental Stimuli: 9, 17, 23, 26

Appendix 11 Fractional Nitric Oxide in Inhaled Breath

Fractional nitric oxide in inhaled breath (F_{ENO}) data of high and consistent quality must be obtained for proper interpretation of the results of this protocol. To these ends, a standard measurement device will be used, and training provided on its use and care; specific operating instruction will also be provided.

Equipment

The [REDACTED] device [REDACTED] and all required accessories (eg, test kits) will be provided by Pearl and used by all sites. The [REDACTED] device is suitable for children, approximately 7 to 17 years of age, and adults 18 years and older.

A User Manual will also be provided (electronically, printed, or both) which includes detailed information for installation, use, troubleshooting, and preventive care for the Niox Vero device.

Procedures

Two valid, reproducible F_{ENO} measurements are required, in accordance with testing procedures recommended by the manufacturer and similar to those published by the American Thoracic Society and European Respiratory Society (ATS/ERS 2005). If either or both of the first 2 valid F_{ENO} measurements is < 30 ppb and the measurements are within 2 ppb of each other, or if both measurements are > 30 ppb and within 10% of each other, then the test is considered reproducible and complete.

Two values below or above the measurement range (5-300 ppb) are also considered reproducible. If the reproducibility criteria are not met within the first 2 exhalations, a participant has 2 additional exhalations to satisfy the criteria (up to a total of 4 trials). The examinee's exhalations for which the device does not display a valid reading, ie, exhalations that are either too strong or too weak, or any other reasons for failing to achieve a successful exhalation, will be recorded as attempts. Examinees may not always be able to meet the criteria for a reproducible measurement.

The results of each attempt will be recorded in the appropriate eCRF.

Reference

American Thoracic Society, European Respiratory Society. ATS/ERS recommendations for standardized procedures for the online and offline measurement of exhaled lower respiratory nitric oxide and nasal nitric oxide, 2005. *Am J Respir Crit Care Med.* 2005;171(8):912-930.

Appendix 12 Rules for Evaluation of Abnormal Liver Laboratory Values

INTRODUCTION

During the course of the study the Investigator will remain vigilant for increases in liver biochemistry. The Investigator is responsible for determining whether a subject meets potential Hy's Law (PHL) criteria at any point during the study.

The Investigator participates, together with the Sponsor clinical representatives, in review and assessment of cases meeting PHL criteria to agree whether Hy's Law (HL) criteria are met. Hy's Law criteria are met if there is no alternative explanation for the elevations in liver biochemistry other than Drug-Induced Liver Injury (DILI) caused by study drug.

The Investigator is responsible for recording data pertaining to PHL/HL cases and for reporting AEs and SAEs according to the outcome of the review and assessment in line with standard safety reporting processes.

DEFINITIONS

Potential Hy's Law

The levels of AST or ALT $\geq 3 \times \text{ULN}$ **with** TBL $\geq 2 \times \text{ULN}$ at any point during the study irrespective of an increase in ALP. The elevations do not have to occur at the same time or within a specified time frame.

Hy's Law

The levels of AST or ALT $\geq 3 \times \text{ULN}$ **with** TBL $\geq 2 \times \text{ULN}$, where no other reason, other than the study drug, can be found to explain the combination of increases, eg, elevated ALP indicating cholestasis, viral hepatitis, or another drug. The elevations do not have to occur at the same time or within a specified time frame.

IDENTIFICATION OF POTENTIAL HY'S LAW CASES

In order to identify cases of PHL it is important to perform a comprehensive review of laboratory data for any subject who meets any of the following identification criteria in isolation or in combination:

- ALT $\geq 3 \times \text{ULN}$
- AST $\geq 3 \times \text{ULN}$
- TBL $\geq 2 \times \text{ULN}$

When a subject meets any of the identification criteria in combination, the central laboratory will immediately send an alert to the Investigator and the Sponsor representative.

The Investigator will also remain vigilant for any laboratory reports where the identification criteria are met, the Investigator will:

- Request a repeat of the test (new blood draw) by the central laboratory

When the identification criteria are met from central laboratory results the Investigator will without delay:

- Determine whether the subject meets PHL criteria by reviewing all laboratory reports including previous visits
- Notify the Sponsor representative

FOLLOW-UP

Potential Hy's Law Criteria not met

If the subject does not meet PHL criteria the Investigator will:

- Inform the Sponsor representative that the subject has not met PHL criteria
- Perform follow up on subsequent laboratory results according to the guidance provided in the Clinical Study Protocol

Potential Hy's Law Criteria met

If the subject does meet PHL criteria the Investigator will:

- Notify the Sponsor representative who will then inform the central Study Team

The Medical Monitor contacts the Investigator, to provide guidance, discuss, and agree on method of follow up and the continuous review of data. Subsequent to this contact, the Investigator will:

- Monitor the subject until liver biochemistry parameters and appropriate clinical symptoms and signs return to normal or baseline levels, or as long as medically indicated.
- Investigate the etiology of the event and perform diagnostic investigations as discussed with the Sponsor Medical Monitor.
- If at any time (in consultation with the Sponsor Medical Monitor) the PHL case meets serious criteria, report the event as an SAE using standard reporting procedures.

REVIEW AND ASSESSMENT OF POTENTIAL HY'S LAW CASES

The instructions in this section should be followed for all cases where PHL criteria are met.

No later than 2 weeks after the biochemistry abnormality was initially detected, the Sponsor Medical Monitor contacts the Investigator in order to review available data and agree on whether there is an alternative explanation for meeting PHL criteria other than DILI caused by the study drug. The Sponsor Medical Monitor and other subject matter experts (as appropriate) will collaborate in the review and assessment of these cases.

According to the outcome of the review and assessment, the Investigator will follow the instructions below.

If there is an agreed alternative explanation for the ALT or AST and TBL elevations, a determination of whether the alternative explanation is an AE will be made and subsequently whether the AE meets the criteria for an SAE:

- If the alternative explanation is an AE/SAE, record the AE /SAE in the eCRF according to the Sponsor's standard reporting procedures.
- If the alternative explanation is not an AE, record the alternative explanation on the comment form within the eCRF.

If it is agreed that there is no explanation that would explain the ALT or AST and TBL elevations other than the study drug:

- Report as an SAE (report term "Hy's Law case") according to Sponsor standard processes
 - The "Medically Important" serious criterion should be used if no other serious criteria apply
 - As there is no alternative explanation for the HL case, a causality assessment of "related" should be assigned

If, there is an unavoidable delay of over 2 weeks in obtaining the information necessary to assess whether or not the case meets the criteria for HL, then it is assumed that there is no alternative explanation. Until an informed decision can be made, the following procedure should be followed:

- Report as an SAE (report term "Potential Hy's Law") applying serious criteria and causality assessment as per above.

Continue follow up and review according to the agreed plan. Once the necessary supplementary information is obtained, repeat the review and assessment to determine whether HL criteria are met. Update the SAE Report Form according to the outcome of the review.

Appendix 13 Sponsor Signatory

Study Title: A Randomized, Double-Blind, Parallel Group, Multi-Center
24-Week Study Comparing the Efficacy and Safety of Three
Doses of PT001 to Placebo and Open-label Spiriva® Respimat®
in Subjects With Persistent Asthma

Study Number: PT001102-04

Final Date: 08 March 2019

Signature:



Date: 08 MARCH 2019

Name:



Title:

Pearl – A member of the AstraZeneca

Group

Appendix 14 Investigator's Agreement and Signature Page

Study Title: A Randomized, Double-Blind, Parallel Group, Multi-Center 24-Week Study Comparing the Efficacy and Safety of Three Doses of PT001 to Placebo and Open-label Spiriva[®] Respimat[®] in Subjects With Persistent Asthma

Study Number: PT001102-04

Final Date: 08 March 2019

I agree:

- a. To assume responsibility for the proper conduct of the study at this site.
- b. To conduct the study in compliance with the protocol and with any other study conduct procedures provided by Pearl Therapeutics, Inc. (hereafter referred to as Pearl).
- c. Not to implement any changes to the protocol without agreement from the Sponsor and prior review and written approval from the IRB/IEC, except where necessary to eliminate an immediate hazard to the subjects, or for administrative aspects of the study (where permitted by all applicable regulatory requirements).
- d. That I am aware of, and will fully comply with GCP and all applicable regulatory requirements.
- e. That I am thoroughly familiar with the appropriate use of the investigational product(s), and other information provided by the Sponsor including, but not limited to, the following: the protocol and the current Investigator Brochure (IB).
- f. To ensure that all persons assisting me with the study are qualified, adequately informed about the investigational product(s) and of their study-related duties and functions.
- g. To supply Pearl with any necessary information regarding ownership interest and financial ties; to promptly update this information if any relevant changes occur during the course of the study and for 1 year following completion of the study; and agree that Pearl may disclose any information it has about such ownership interests and financial ties to regulatory authorities.
- h. I agree to report all information or data in accordance with the protocol and any other study conduct procedures provided by Pearl.
- i. That since the information in this protocol and IB is confidential, I understand that its disclosure to any third parties, other than those involved in approval, supervision or conduct of the study is prohibited.
- j. To accurately transfer all required data from each subject's source document to the eCRFs. The eCRFs will be provided to the Sponsor in a timely manner at the completion of the study, or as otherwise specified by the Sponsor.
- k. To allow authorized representatives of Pearl or regulatory authority representatives to conduct on-site visits to review, audit and copy study documents. I will personally meet with these representatives to answer any study-related questions.

Signature: _____

Date: _____

Name: _____

Site Name: _____